



*An Online PDH Course
brought to you by
CEDengineering.com*

Seismic Design of Cast-in-Situ Concrete Diaphragms According to ACI 318-19 & ASCE 7-22

Course No: S05-017
Credit: 5 PDH

Ibrahim M. Metwally, Ph.D., P.E



Continuing Education and Development, Inc.

P: (877) 322-5800
info@cedengineering.com

www.cedengineering.com

Table of Contents

1. Introduction	1
2. The Roles of Diaphragms	2
3. Diaphragm Components	4
4. Diaphragm Behavior and Design Principles	7
4.1 Dynamic Response of Buildings and Diaphragms	7
4.2 Intended and Observed Behavior	11
4.3 Building Code Provisions	11
4.4 Other Approaches	14
5. Building Analysis Guidance	15
5.1 Design Lateral Forces.....	15
5.1.1 Diaphragm Design Forces.....	15
5.1.2 Collector Design Forces.....	16
5.1.3 Irregular Structural Systems.....	17
5.1.4 Use of Dynamic Analysis	17
5.2 Transfer Forces.....	18
5.3 Diaphragm Stiffness Modeling	19
5.4 Special Conditions	21
5.4.1 Diaphragms with Openings	21
5.4.2 Ramps	21
5.5 Displacement Compatibility for Flexible Diaphragms.....	22
6. Diaphragm Analysis Guidance.....	23
6.1 Diaphragm Modeling and Analysis Approaches	23
6.2 Beam Models.....	24
6.2.1 Analysis of Moments, Shears, and Reactions	24
6.2.2 Internal Forces in Beam Models.....	27
6.3 Strut-and-Tie Models.....	29
6.4 Finite Element Models.....	31
6.5 Diaphragms with Large Openings.....	32
6.6 Partial-Depth Collectors	33
6.7 Diaphragm Shear Distribution	35
6.8 Diaphragm-to-Vertical-Element Force Transfer.....	35
6.9 Diaphragm Slabs on Ground.....	36

7. Design Guidance	37
7.1 Load and Strength Reduction Factors.....	37
7.2 Tension and Compression Chords	39
7.3 Diaphragm Shear	42
7.4 Force Transfer between Diaphragm and Vertical Elements	43
7.5 Special Cases	47
7.5.1 Openings Adjacent to Vertical Elements	47
7.5.2 Re-Entrant Corners	48
7.5.3 Steps and Depressions	49
7.5.4 Extension of Collectors into Diaphragms	50
7.5.5 Reinforcement Development.....	51
8. Additional Requirements	51
8.1 Materials Properties.....	51
8.2 Special Inspection.....	52
8.3 Bracing Columns to Diaphragms.....	53
8.4 Interaction of Diaphragm Reinforcement with Vertical Elements.....	54
9. Detailing and Constructability Issues	55
9.1 Diaphragm Reinforcement	55
9.2 Collector and Chord Detailing.....	55
9.3 Confinement.....	57
9.4 Shear Transfer	58
9.5 Mechanical Splices	59
9.6 Conduits and Embedded Services	60
9.7 Location of Construction Joints	61
References.....	62

List of Figures

Figure 1. Isometric view of a basic building structural system comprising horizontal elements (diaphragms), vertical elements (walls and frames), and foundation.....	1
Figure 2. Role of diaphragms.	4
Figure 3. Moment and shear at a section cut	5
Figure 4. Collectors	6
Figure 5. Collector transferring shear from the wall into the podium diaphragm	7

Figure 6. ASCE 7 design response spectrum showing spectral response acceleration as a function of vibration period.....	8
Figure 7. Design forces for vertical elements and diaphragms.	9
Figure 8. Diaphragms develop transfer forces by imposing displacement compatibility between different vertical elements of the seismic force-resisting system.....	10
Figure 9. Diaphragm transfer forces at irregularities in the vertical elements of the seismic force-resisting system.....	10
Figure 10. Force RA transferred between diaphragm and wall can be obtained by section cuts through wall.....	19
Figure 11. Effect of diaphragm deformations on distribution of displacements and forces	20
Figure 12. Equivalent beam-on-springs model	25
Figure 13. Corrected equivalent beam model	27
Figure 14. Force transfer where a collector is wider than the vertical element to which it transmits diaphragm shears.	29
Figure 15. Strut-and-tie model at force transfer to basement wall	30
Figure 16. Challenging design conditions.....	31
Figure 17. Irregularly shaped diaphragm	32
Figure 18. Diaphragms with large openings.....	33
Figure 19. Partial-depth collector	34
Figure 20. collector force directly to shear wall.....	36
Figure 21. Locations of non-prestressed reinforcement resisting.....	39
Figure 22. Confinement reinforcement in axial struts around openings.....	41
Figure 23. Shear reinforcement, collector reinforcement, and shear friction reinforcement...	43
Figure 24. Shear reinforcement, collector reinforcement, and shear friction reinforcement...	46
Figure 25. Reinforcement to transfer collector force around an opening.	48
Figure 26. Reinforcement associated with re-entrant corners	49
Figure 27. Collector reinforcement passing through a step and depression.....	50
Figure 28. Collector detailing.....	56
Figure 29. A long collector with confinement reinforcement	57
Figure 30. Confinement of a collector	58
Figure 31. Form-face couplers for dowel anchorage.	59
Figure 32. Embedded conduit.....	60
Figure 33. Conflict between the location of collector reinforcing with a nonstructural component.	61

1. Introduction

Building structures generally comprise a three-dimensional framework of structural elements that are configured to support gravity and lateral loads. Although the complete three-dimensional system acts integrally to resist loads, structural engineers commonly conceive of the seismic force-resisting system as being composed of vertical elements, horizontal elements, and the foundation (Figure 1). The vertical elements extend between the foundation and the elevated levels, providing a continuous load path to transmit gravity, wind, and seismic forces from the upper levels to the foundation. The horizontal elements typically consist of diaphragms, including any chords and collectors. Diaphragms transmit lateral forces from the floor system to the vertical elements of the structural system. They also tie the vertical elements together and thereby stabilize these elements and transmit forces among them. Diaphragms are thus an essential part of the structural system and require design attention by the structural engineer to ensure the structural system performs adequately under design loadings.

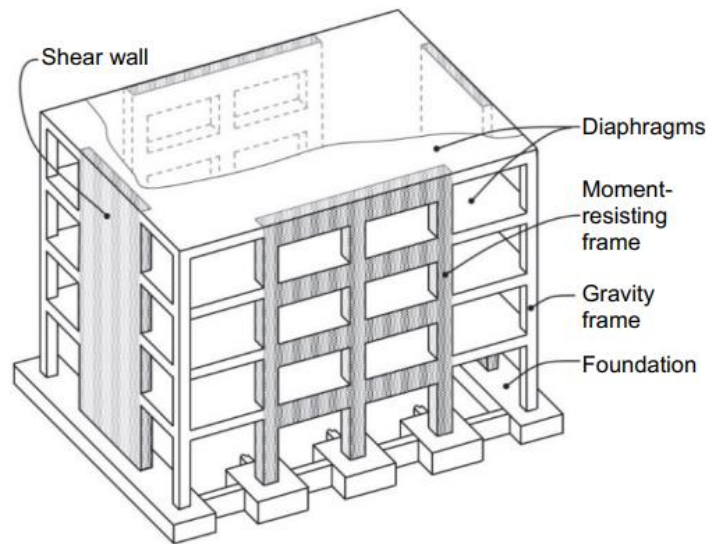

Figure 1. Isometric view of a basic building structural system comprising horizontal elements (diaphragms), vertical elements (walls and frames), and foundation.

Diaphragms are required to be designed as part of the seismic force-resisting system of every new building assigned to Seismic Design Category B, C, D, E, or F in the United States. Although horizontal elements can consist of truss elements or horizontal diagonal bracing, in

most cases diaphragms are constructed as essentially solid, planar elements made of wood, steel, concrete, or combinations of these. Concrete diaphragms can be conventionally reinforced or prestressed, and can be cast-in-place concrete, topping slabs on metal deck or precast concrete, or interconnected precast concrete without topping, although the last system is seldom used in structures assigned to Seismic Design Category D, E, or F. The scope of this Guide is restricted to cast-in-place concrete diaphragms, either conventionally reinforced or prestressed. However, many of the concepts that are presented here apply equally to other diaphragm types.

The design requirements for cast-in-place concrete diaphragms are presented in the American Concrete Institute 318, Building Code Requirements for Structural Concrete (ACI 2019). The requirements relate to materials, strength, detailing, and construction inspection for diaphragms in any building plus additional requirements for buildings assigned to Seismic Design Category D, E, or F.

This course is divided into the following Sections:

- Section 2, Section 3, and Section 4 introduce the role of horizontal diaphragms within the structural system of buildings and diaphragm design principles.
- Section 5 and Section 6 present analysis guidance.
- Section 7, Section 8, and Section 9 describe important proportioning, additional requirements, and detailing and constructability issues for cast-in-place concrete diaphragms.

2. The Roles of Diaphragms

Diaphragms serve multiple roles to resist gravity and lateral forces in buildings. Figure 2 illustrates several of these roles for a building with a podium level at grade and with below-grade levels. The main roles highlighted in ACI 318-19 include the following:

Diaphragm in-plane forces. Lateral forces from wind, earthquake, and horizontal fluid or soil pressure generate in-plane shear, axial, and bending actions in diaphragms as they span between, and transfer forces to, vertical elements of the lateral force-resisting system. For earthquake loading, inertial forces are generated within the diaphragm and tributary portions of walls, columns, and other elements. These forces are then transferred through the diaphragm to the vertical elements. For buildings with subterranean levels, soil pressure generates out-of-plane forces on basement walls, which are supported by diaphragms.

Diaphragm transfer forces. Vertical elements of the lateral force-resisting system may have different properties over their height, or their planes of resistance may change from one story to another, creating force transfers between vertical elements. A common location where planes of resistance change is at grade level of a building with an enlarged subterranean plan (Figure 2); at this location, forces may transfer from the narrower tower into the basement walls through a podium diaphragm. The top of the podium is not always at grade level, and in such cases, large force transfers might occur both at the top of podium and at grade level.

Anchorage forces. Wind pressure and earthquake shaking can generate lateral forces in vertical framing and nonstructural elements, such as cladding. These forces are transferred from the elements where the forces are developed to the diaphragms providing lateral support through connections.

Column bracing forces. Diaphragms connect to vertical elements of the structural system at each floor level, thereby providing lateral support to resist buckling as well as second-order forces associated with axial vertical forces acting through lateral displacements. Architectural configurations can sometimes require inclined columns, which can result in large horizontal thrusts acting within the plane of the diaphragms because of gravity and overturning actions (Figure 2). The thrusts can act in different directions depending on orientation of the column and whether it is in compression or tension. Where these thrusts are not balanced locally by other elements, they must be transferred into the diaphragm and transmitted to other elements of the lateral force-resisting system.

Diaphragm out-of-plane forces. Most diaphragms are part of floor and roof framing and, therefore, support gravity loads and out-of-plane forces because of wind uplift pressure on a roof slab and vertical acceleration due to earthquake effects.

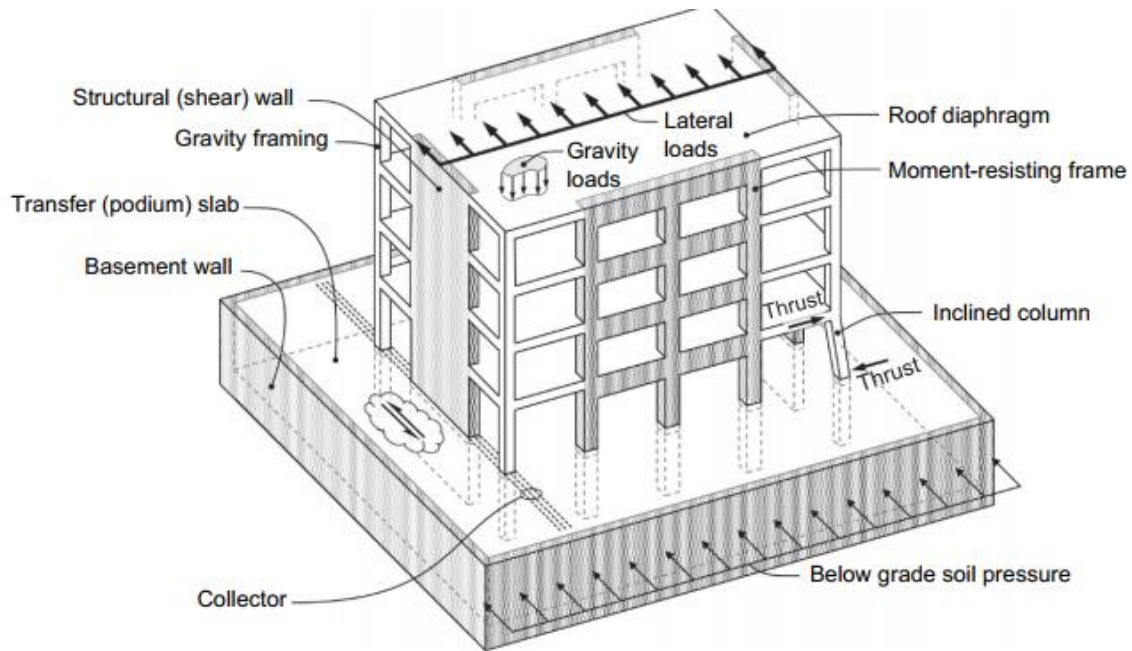

Figure 2. Role of diaphragms.

3. Diaphragm Components

Diaphragms are commonly composed of various components, including the diaphragm slab, tension and compression chords, collectors, and connections to the vertical elements.

Figure 3 illustrates a simplified model of how a diaphragm resist in-plane load. See Section 6 for additional diaphragm models. In **Figure 3a**, a solid rectangular diaphragm spans between two end walls, with lateral inertial loading indicated schematically by the distributed load at the top of the figure. The diaphragm can be modeled as a beam spanning between two supports, with reactions and shear and moment diagrams as shown in **Figure 3c**.

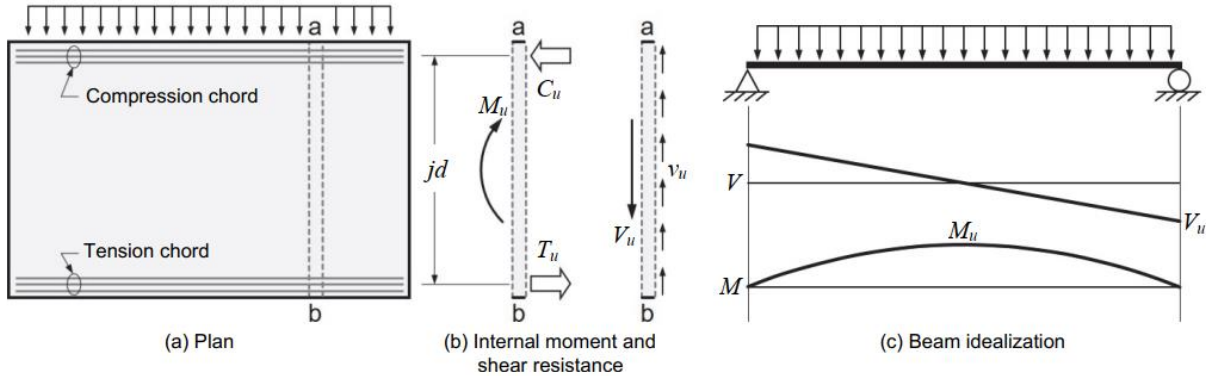

Figure 3. Moment and shear at a section cut

Figure 3b shows two sketches of a narrow strip ab cut from the diaphragm. In the left-hand sketch, the in-plane bending moment (M_u) is resisted by a tension (T_u) and compression (C_u) couple acting through an internal moment arm jd . Elements designed into the boundary of the diaphragm to resist these tension and compression forces are known as the tension chord and the compression chord, respectively.

If the diaphragm bending moment is resisted entirely by tension and compression chords at the boundaries of the diaphragm as shown in **Figure 3a**, then equilibrium requires that the diaphragm in-plane shear be distributed uniformly along the depth of the diaphragm. This is shown in the right-hand sketch of strip ab in **Figure 3b**. Tension and compression elements called collectors are required to “collect” this distributed shear and transmit it to the walls.

A collector can transmit all of its forces into the ends of the walls as shown on the right side of **Figure 4a**, or if the forces and resulting congestion are beyond practical limits, the collector can be spread into the adjacent slab, as shown on the left side of **Figure 4a**. Section 6.2.2 discusses the effective width of a collector spread into a slab.

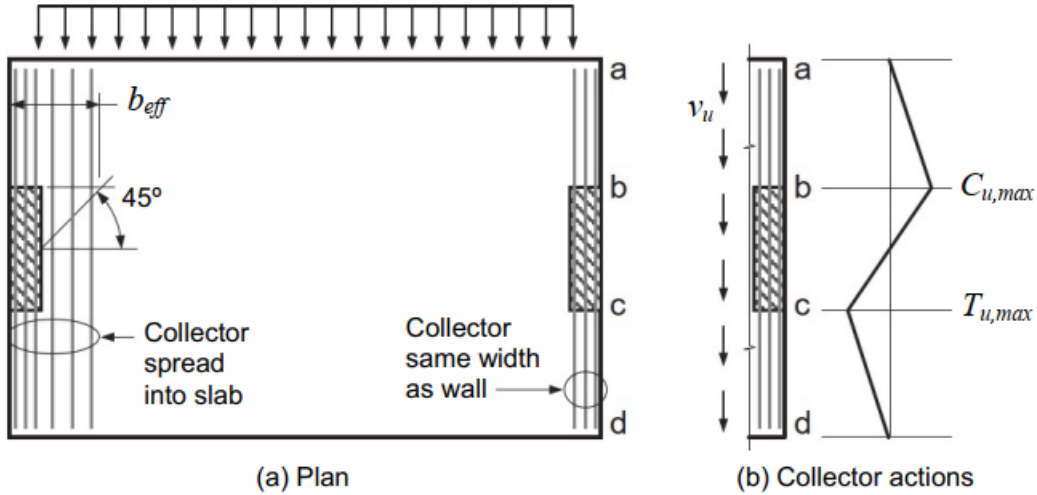

Figure 4. Collectors

Figure 4b illustrates how the tension and compression forces in the collector are determined for the case where the width of the collector is the same as that of the wall. Starting at a free end, the tension or compression force increases linearly as shear is transferred into the collector.

If the inertial forces from cladding or any other perimeter elements are required to be collected, then the collector force might not be zero at the ends. The collector forces need to be transferred into the vertical elements of the seismic force-resisting system. This is shown as a gradual transition in collector force along length bc. Section 6 discusses this force transfer and the added considerations where the collector is wider than the wall.

Diaphragms also transfer force among vertical elements of the seismic force-resisting system. A very common example is where a wall intersects a podium slab in a building. In this case, shear is transferred from the wall into the diaphragm and from there to other elements, such as basement walls (**Figure 2**). This element transferring the force from the wall to the diaphragm is a collector (**Figure 5**). A collector that takes force from a vertical element and distributes it into the diaphragm is referred to as a distributor.

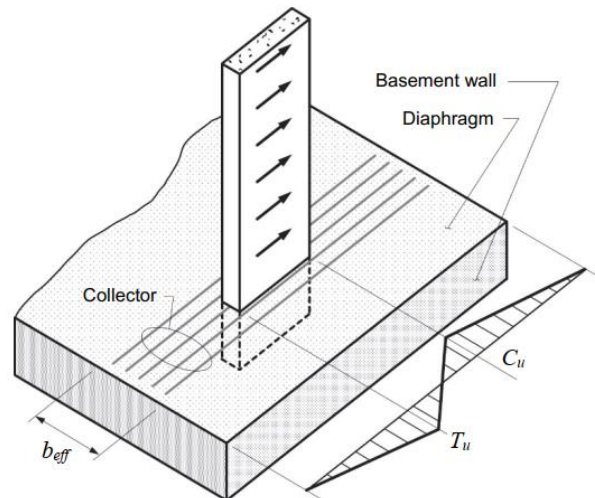

Figure 5. Collector transferring shear from the wall into the podium diaphragm

4. Diaphragm Behavior and Design Principles

4.1 Dynamic Response of Buildings and Diaphragms

Fundamental studies of structural dynamics (e.g., Chopra 2005) show that the dynamic response acceleration of an oscillator (a structure with one degree of freedom) subjected to earthquake ground motion varies with time and that the peak value will be a function of the vibration period of the oscillator. The smooth design response spectrum of ASCE 7 (**Figure 6**) represents this period dependency.

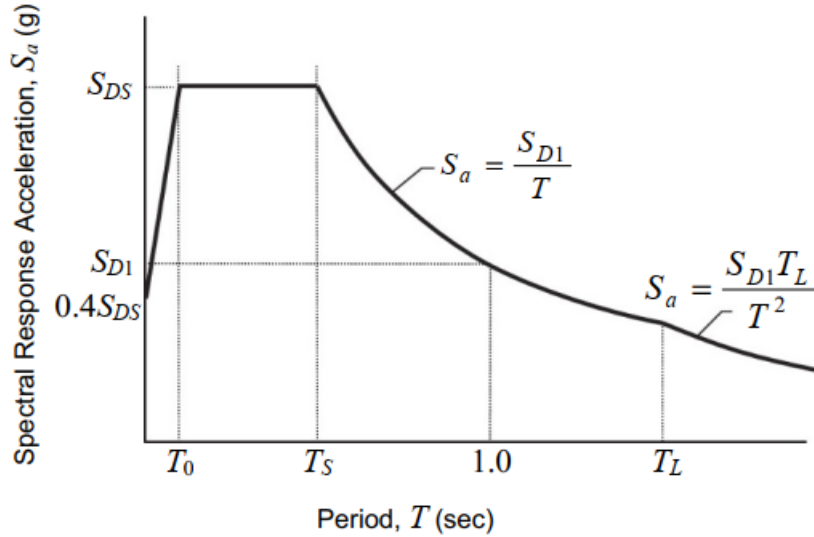

Figure 6. ASCE 7 design response spectrum showing spectral response acceleration as a function of vibration period.

In **Figure 6**, the term S_{DS} represents the design spectral response acceleration for short-period structures. The peak ground acceleration, which is the spectral acceleration at $T = 0$, has an assigned value of $0.4S_{DS}$. The ratio of the peak response acceleration to the peak ground acceleration is called the response acceleration magnification. Its value for short-period structures is 2.5 in this design spectrum.

Multi-story buildings have many vibration modes, each with a unique vibration period. The total acceleration response is the sum of the responses of each vibration mode. Studies of building responses (e.g., Shakal et al. 1995; Rodriguez et al. 2007) show response acceleration magnification is around 2.5 for buildings responding essentially elastically. For buildings responding with more inelastic behavior, a lower response acceleration magnification generally is obtained.

One important observation about multi-story buildings is that, because of higher-mode effects, the different floors trace out different acceleration histories. Each of the floors should be designed to resist the inertial force corresponding to the peak response acceleration for that floor. It would be overly conservative to design the vertical elements of the seismic force-resisting system for the sum of all the individual peaks, however, because each floor reaches its peak response at a different time during the dynamic response. Simple modeling of a three-story building, where n equals 3, with lumped weights, w_i , acting at each story level located at a

distance, h_i , above ground level provides two sets of design forces commonly specified for design (**Figure 7**):

- (a) One set of design forces, F_x , is applied to the design of the vertical elements of the seismic force-resisting system.
- (b) A second set of design forces, F_{px} , is applied to the design of the diaphragms.

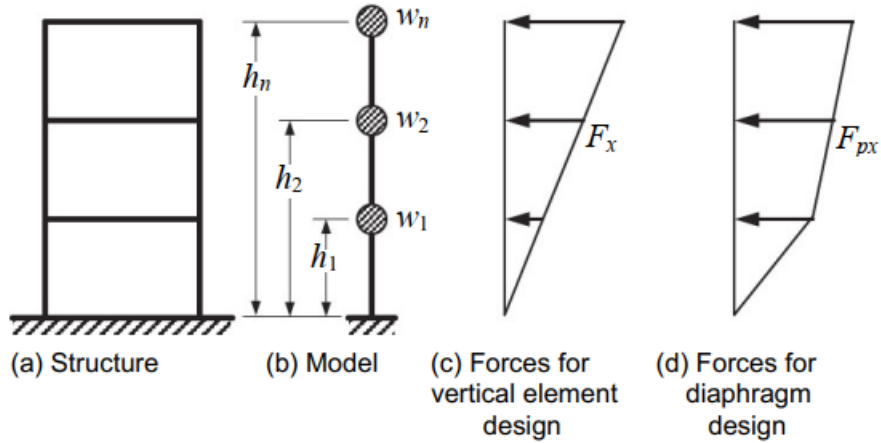

Figure 7. Design forces for vertical elements and diaphragms.

In addition to resisting inertial forces (tributary mass times floor acceleration), diaphragms also must be able to transfer forces between different vertical elements of the seismic force-resisting system. For example, frames and walls that are acting independently have different displacement profiles under lateral loads; however, if interconnected by a diaphragm, the diaphragm develops internal forces as it imposes displacement compatibility (**Figure 8**). Almost all buildings have force transfers of this type that should be investigated and considered in design. Considering only diaphragm actions because of F_{px} is, in general, not sufficient.

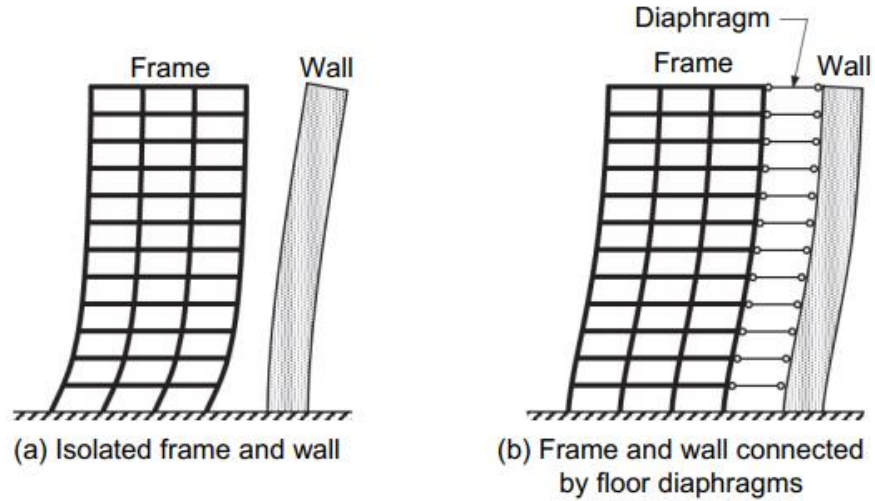

Figure 8. Diaphragms develop transfer forces by imposing displacement compatibility between different vertical elements of the seismic force-resisting system.

Sometimes the largest diaphragm transfer forces are at offsets or discontinuities of the vertical elements of the seismic force-resisting system. **Figure 9** shows a common example involving vertical discontinuities at (a) a setback in the building profile, and (b) a podium level at grade.

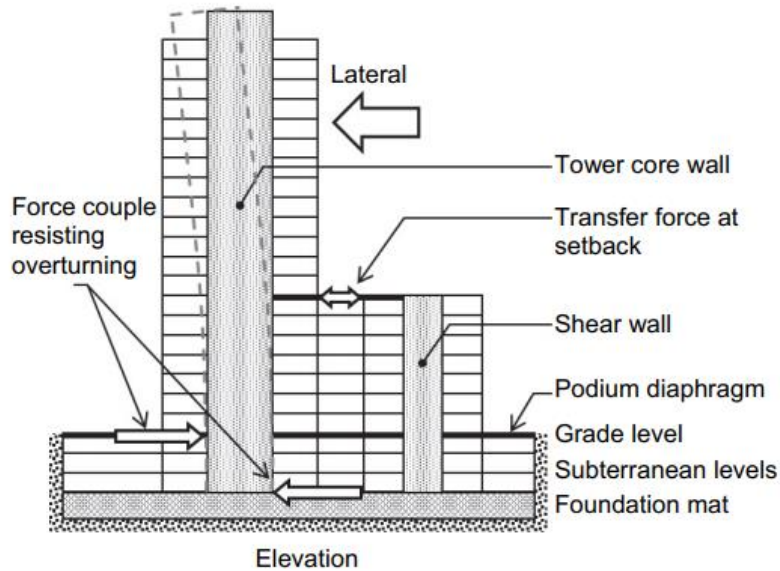

Figure 9. Diaphragm transfer forces at irregularities in the vertical elements of the seismic force-resisting system

A typical configuration in parking structures uses the diaphragm as parking surface and ramp, with the diaphragm split longitudinally and inclined in some locations. Other configurations typically result in long distances between vertical elements of the seismic force resisting system. Consequently, diaphragm segments can be relatively long and narrow. Lateral deformations in these flexible diaphragms contribute to dynamic response and can result in diaphragm displacements significantly exceeding displacements of the vertical elements (Fleischman et al. 2002). Design of gravity columns needs to accommodate the increased displacements. In addition, the inclined ramps can act as unintended diagonal braces that interrupt intended framing action of the vertical elements and result in considerable axial load in the diaphragm. Expansion joints can relieve this action if provided at every level. For more information, see the Structural Engineers Association of California (SEAOC) publication, *The SEAOC Blue Book: Seismic Design Recommendations* (SEAOC 2009). For an abridged version of this document, see *Seismic Design of Concrete Parking Structure Ramps* (SEAOC 2010).

4.2 Intended and Observed Behavior

One of the principles of earthquake-resistant design is to maintain relatively stiff and damage-free diaphragms that are capable of tying together the vertical elements of the seismic force-resisting system. Thus, diaphragms are designed for essentially linear behavior under the Design Earthquake loading; that is, minor nonlinearity may be acceptable, but significant inelastic response, if it occurs at all, will be restricted to the vertical elements. To achieve this goal, seismic design of a diaphragm should clearly identify the load paths to the vertical elements and should aim to provide diaphragm strength along that load path at least equal to the maximum force that can be developed by the vertical elements.

Design approaches for cast-in-place diaphragms have been relatively effective in limiting diaphragm damage, with only a few cases of observed damage following earthquakes. Some cases of fracture of diaphragm connections to shear walls have been observed (Corley et al. 1996), leading to code changes for collector design. Other types of concrete diaphragms, especially precast diaphragms with or without topping slabs, require greater attention to proportions and details to achieve the goal of essentially elastic behavior.

4.3 Building Code Provisions

Seismic design of diaphragms is required for all buildings in Seismic Design Category B through F. ASCE 7 §12.10 contains the main provisions for diaphragm design. The design

must consider the lateral seismic forces F_x , the diaphragm design forces F_{px} , and any transfer forces associated with response under the design seismic loading.

The lateral seismic forces F_x are determined in the analysis of the vertical elements of the seismic force resisting system (**Figure 7c**). These forces typically are determined from either the Equivalent Lateral Force Procedure (ASCE 7 §12.8) or the Modal Response Spectrum Analysis (ASCE 7 §12.9.1), although the Linear Response History Analysis (ASCE 7 §12.9.2) or the Nonlinear Response History Procedures of ASCE 7 Chapter 16 also can be used. These lateral seismic forces represent the overall building design lateral force distribution, the sum of which results in the design base shear V .

As discussed in Section 4.1, the lateral seismic forces F_x do not necessarily reflect the estimated maximum force induced at a particular diaphragm level. Thus, ASCE 7 §12.10.1.1 also requires the diaphragm to be designed for the diaphragm design force F_{px} (**Figure 7d**). Associated design requirements typically are evaluated by applying F_{px} to one floor at a time rather than all floors simultaneously, using either simplified models (Section 6.1) or the overall building model. Approaches to diaphragm analysis that include the use of the overall building model are discussed by Sabelli et al. (2009a; 2009b).

Diaphragms must also be designed to resist the transfer forces that develop because of framing interaction among different vertical elements. The biggest transfer forces usually occur at or near levels with horizontal offsets or changes in mass and stiffness of the vertical seismic force-resisting system. The design also must consider any other forces, such as those induced by hydrostatic pressures and sloping columns as discussed in Section 2. These effects are usually identified using the overall building model rather than individual diaphragm models.

For structures having horizontal structural irregularity Type 4 (out-of-plane offset irregularity) per ASCE 7 Table 12.3-1, the transfer forces from the vertical seismic force-resisting elements above the diaphragm to other vertical seismic force-resisting systems below the diaphragm are required to be multiplied by the overstrength factor Ω_o and added to the diaphragm inertial forces F_{px} . ASCE 7 does not address amplification of transfer forces in diaphragms with in-plane offsets, such as illustrated at the setback of the building in **Figure 9**. This Guide recommends applying the same procedure for this condition.

Failure of some connections between diaphragms and walls in the 1994 Northridge earthquake led to code changes for collectors. According to ASCE 7 §12.10.2, collectors must be capable of transferring the seismic forces originating in other portions of the structure to the element providing the resistance to those forces. For structures assigned to Seismic Design Category C, D, E, or F, collectors including splices and connections to resisting elements are required to resist the load combinations including overstrength factor Ω_o . In the load combinations, the lateral seismic load effect is either $\Omega_o F_x$ or $\Omega_o F_{px}$, whichever produces the larger effect. Transfer forces are added to those calculated using ASCE 7 §12.10.2 and are subject multiplication by either the overstrength factor or the redundancy factor, depending upon the specific condition being evaluated (Section 5.1.2).

Alternative Design Provisions in ASCE 7-22

ASCE 7-22 introduces an alternative procedure for determining the required diaphragm design inertial forces F_{px} . The alternative design provisions are mandatory for precast concrete diaphragms assigned to Seismic Design Category C, D, E, or F. The alternative design provisions are optional for precast concrete diaphragms in buildings assigned to Seismic Design Category B, and buildings in any Seismic Design Category with either cast-in-place concrete diaphragms or wood-sheathed diaphragms supported by wood diaphragm framing. Diaphragm acceleration coefficients are calculated at the base of the structure, at a height equal to 80 percent of the total height of the structure, and at the top of the structure. Acceleration coefficients at intermediate levels are linearly interpolated between these points. The design force is taken as the acceleration coefficient times the seismic mass tributary to the level divided by diaphragm reduction factor R_s . The reduction factors are material-specific and take into consideration both the system ductility and over-strength.

The diaphragm design force reduction values for cast-in-place concrete diaphragms are specified as $R_s = 1.5$ for shear-controlled and $R_s = 2.0$ for flexure-controlled. A flexure-controlled diaphragm provides sufficient shear capacity in all locations to develop the maximum probable flexural strength. Diaphragms that are not flexure-controlled are considered shear-controlled.

For many structures with cast-in-place concrete diaphragms, the design force levels determined using the alternative provisions are similar to those determined using the baseline method. The exception is in the top 20 percent of the height of some structures where the alternate method results in higher required diaphragm strengths.

Once the forces are determined using the ASCE 7 provisions, reinforced concrete diaphragms, and their connections must be designed to resist all shears, moments, and axial forces, including effects of openings and other discontinuities. Chapter 12 of ACI 318 presents the general requirements for diaphragm design. ACI 318 §18.12 presents additional requirements applicable to buildings assigned to Seismic Design Category D, E, or F.

To reduce the likelihood that shear strength of a diaphragm will be less than the shear strength of the vertical elements to which it delivers its forces, ACI 318 §21.2.4.2 requires that the strength reduction factor ϕ for diaphragm shear not exceed the minimum ϕ used for shear design of the vertical elements of the seismic force-resisting system. For example, if all the vertical elements of the seismic force-resisting system are shear walls that use a value of $\phi = 0.75$ for shear, the value of ϕ for diaphragm shear design is also 0.75; if the shear walls use a value of $\phi = 0.6$ for shear, as is required if the wall design shear is not adjusted based on the provided wall moment strength, then the value of ϕ for diaphragm shear design is also 0.6. See additional requirements for the diaphragm ϕ factor in Section 7.1.

4.4 Other Approaches

There are alternative approaches for determining design forces in diaphragms and collectors. In performance-based seismic design, a nonlinear response history analysis typically is used. For this purpose, ground motions are selected and scaled to represent the seismic hazard for the site. Diaphragm design forces may be caused by diaphragm accelerations, transfer forces, or both. Consequently, the ground motion selection and scaling procedure need to take into account the range of vibration periods that affect these responses. Diaphragm accelerations and the resulting forces can be determined directly from the analysis. If diaphragms are modeled as finite elements, section cuts can be used to track diaphragm forces at each time step. If diaphragms are modeled as rigid elements, section cuts through vertical elements above and below the diaphragm can be used to identify transfer forces.

Capacity-based design is another way to determine diaphragm design forces. This approach uses the maximum force that can be delivered to a diaphragm by the framing system as the design force and by the reliable resistance as the design strength. The approach may be suitable for levels with significant transfers (such as podium slabs) but overly conservative for other levels. Where capacity-based design is used, structural engineers should consider expected material properties, multiple failure mechanisms, multiple load patterns, and appropriate strength calculation procedures so that the resulting demands and capacities safely cover the range of combinations that can be reasonably expected.

Nonlinear Dynamic Analysis Guidance

Nonlinear response history analysis is sometimes used to determine forces in collectors and their connections, as an alternative to using Ω_o -amplified forces F_x and F_{px} . This approach can be acceptable if the analysis and design approach are established to achieve the intent of the building code that the collector is not the weak link in the load path. Collector demands should be determined using appropriate estimates of material properties (for example, expected material properties) and should consider the variability in demands produced by different earthquake ground motions. Likewise, the collector design strengths should be determined using a conservative estimate (for example, the design strength using nominal material properties and the code strength reduction factor). By appropriate selection of the design demands and strengths, an acceptably low probability of failure can be achieved.

See also NEHRP Seismic Design Technical Brief No. 4 (Deierlein et al. 2010).

5. Building Analysis Guidance

5.1 Design Lateral Forces

5.1.1 Diaphragm Design Forces

ASCE 7 §12.10 requires diaphragms to be designed for inertial forces determined as the maximum of (a) and (b) as follows:

(a) The design seismic force from the structural analysis of the seismic force-resisting system. This is commonly taken as the force F_x from the Equivalent Lateral Force Procedure, where:

$$F_x = C_{vx} V \quad (\text{ASCE 7 Eq. 12.8-11})$$

$$C_{vx} = \frac{w_x h_x^k}{\sum_{i=1}^n w_i h_i^k} \quad (\text{ASCE 7 Eq. 12.8-12})$$

(b) The diaphragm design force F_{px} , where

$$F_{px} = \frac{\sum_{i=x}^n F_i}{\sum_{i=x}^n w_i} w_{px} \quad (\text{ASCE 7 Eq. 12.10-1})$$

but not less than

$$F_{px,\min} = 0.2 S_{DS} I_e w_{px} \quad (\text{ASCE 7 Eq. 12.10-2})$$

and need not exceed

$$F_{px,\max} = 0.4 S_{DS} I_e w_{px} \quad (\text{ASCE 7 Eq. 12.10-3})$$

The lateral force F_i used in ASCE 7 Eq. 12.10-1 is often based on the Equivalent Lateral Force Procedure defined above. However, F_i can be the force at level i from Modal Response Spectrum Analysis.

Where the diaphragm is required to transfer design seismic force from vertical resisting elements above the diaphragm to other vertical resisting elements below the diaphragm because of offsets or differences in relative lateral stiffness in the vertical elements, these transfer forces are added to those determined from ASCE 7 Eq. 12.10-1. As discussed in Section 4.3, transfer forces due to a Type 4 horizontal structural irregularity need to be increased by the overstrength factor Ω_o . For structures assigned to Seismic Design Category D, E, or F, the redundancy factor ρ applies to the diaphragm design.

For inertial forces calculated in accordance with ASCE 7 Eq. 12.10-1, ρ is taken equal to 1.0. For transfer forces, ρ is the same as that used for the vertical elements of the seismic force-resisting system. However, where the Ω_o factor is applied, ρ is taken equal to 1.0.

5.1.2 Collector Design Forces

For structures assigned to Seismic Design Category C, D, E, or F, collector design forces are the maximum of (a), (b), and (c) as follows:

- (a) Forces resulting from application of F_x using the four load combinations with overstrength factor Ω_o of ASCE 7 §12.4.3.2;
- (b) Forces resulting from application of F_{px} using the four load combinations with overstrength factor Ω_o of ASCE 7 §12.4.3.2;
- (c) Forces resulting from application of $F_{px,min}$ in the basic load combinations of ASCE 7 §12.4.2.3.

In (a), forces F_x are applied simultaneously to each level of the overall building analysis model. In (b) and (c), forces F_{px} and $F_{px,min}$ typically are applied one level at a time to the diaphragm under consideration, using either the overall building analysis model or an isolated model of the individual diaphragm.

Provisions for Collector Design Forces

The diaphragm design forces presented in this Guide are in accordance with the 2016 edition of ASCE 7. Although the overall design philosophy of providing essentially elastic response of diaphragms has not changed over the years, the detailed requirements of ASCE 7 have evolved

with time. The user of this Guide should refer to the legally adopted Code to determine the specific requirements enforced for a project.

Transfer forces are to be considered in the design of collectors. As discussed in Section 4.3 and Section 5.1.1, transfer forces due to a Type 4 horizontal structural irregularity need to be increased by the overstrength factor Ω_o . Other irregularities, such as a Type 4 vertical structural irregularity may warrant increasing the transfer forces by the overstrength factor Ω_o in the design of collectors. For all other cases, the redundancy factor ρ applies to transfer forces for the collector design. For transfer forces, ρ is the same as that used for the vertical elements of the seismic force-resisting system. However, where the Ω_o factor is applied, ρ is taken equal to 1.0.

5.1.3 Irregular Structural Systems

For structures assigned to Seismic Design Category D, E, or F, ASCE 7 §12.3.3.4 has additional requirements for systems with particular horizontal or vertical irregularities. These include systems with the following horizontal irregularities: Torsional, Extreme Torsional, Reentrant Corner, Diaphragm Discontinuity, or Out of Plane Offset. It also includes systems with the following vertical irregularity: In-Plane Discontinuity in Vertical Lateral Force-Resisting Element. For these systems, the design forces are to be increased by 25 percent for (1) connections of diaphragms to vertical elements and collectors and (2) collectors and their connections, including connections to the vertical elements. The 25 percent increase does not need to be applied to forces calculated using the overstrength factor. Given this exception, the design of collectors and the connections for a concrete diaphragm are rarely governed by this 25 percent increase.

5.1.4 Use of Dynamic Analysis

When design actions are determined using Modal Response Spectrum Analysis, properly combined diaphragm accelerations obtained from the analysis can be used to calculate the diaphragm design force F_{px} . The accelerations should be scaled by I_e/R . If forces are taken directly from section cuts through the finite elements, it is not always clear how to scale the results, as the ability to separate transfer forces from inertial forces can be compromised.

Scaling Design Forces by I_e/R

Numerical and laboratory studies (Rodriguez et al.2007) indicate that floor accelerations and associated diaphragm actions are underestimated if linear-elastic response quantities are scaled by I_e/R . Better correlation is obtained by using modal spectral response combinations

in which only the first-mode responses are scaled, using a scaling factor I_e / R_M , where R_M represents an effective ductility factor for the system. This approach is the basis of the alternative diaphragm design force level in ASCE 7-16 §12.10.3, as described in the sidebar of Section 4.3. Some currently available software does not permit the use of different scaling factors for different modes, making the implementation of this approach problematic

If a Linear Seismic Response History Procedure is used, diaphragm forces can be based directly on consideration of the peak accelerations from multiple input ground motions, with resulting forces scaled by I_e / R . For some design actions, mean values might be appropriate, while for some other design actions, an amplified value might be appropriate. Los Angeles Tall Buildings Structural Design Council (LATBSDC 2014) and Tall Buildings Initiative (PEER 2010) provide some discussion and methods for the use of nonlinear dynamic analysis in design of collectors.

The minimum diaphragm design force $F_{px,min}$ calculated using ASCE 7 Eq. 12.10-2 would still be applicable if the forces determined from either of the above methods are smaller.

5.2 Transfer Forces

Forces acting between a diaphragm and a vertical element of the seismic force-resisting system usually can be extracted from finite element analysis programs. Where the diaphragm is modeled as semirigid, section cuts can be made through groups of elements to determine forces acting on the group. Where the diaphragm is modeled as rigid, section cuts through the diaphragm cannot be used. Instead, section cuts can be made in the vertical element above and below the diaphragm, and the diaphragm force transferred to the vertical element is the force required to equilibrate the vertical element forces (**Figure 10**). This method works for semirigid diaphragms, as well, although section cuts through the diaphragm elements and nodes of interest usually are more direct. Forces obtained by these procedures include the sum of transfer forces and inertial forces; individual values for transfer and inertial forces can only be estimated in many cases.

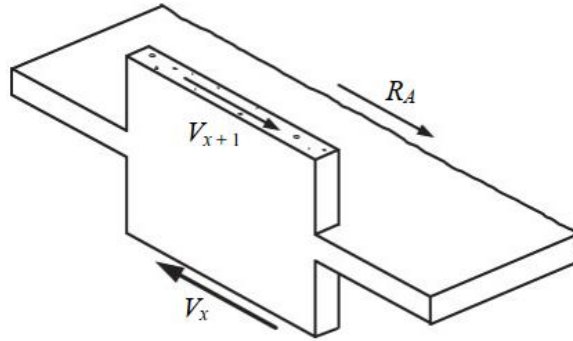

Figure 10. Force R_A transferred between diaphragm and wall can be obtained by section cuts through wall.

The procedures outlined above work directly for the Equivalent Lateral Force Procedure and Response History Procedure. When Modal Response Spectrum Analysis is used, the transfer force for each vibration mode must be determined by the above procedure, and then the design value is obtained by combining the individual modal values using the square root of the sum of the squares or complete quadratic combination methods.

Transfer Forces

*This Guide emphasizes consideration of transfer forces where they are most prominent, such as at podium levels and setbacks of vertical elements. Transfer forces also occur in seemingly regular buildings such as the frame-wall structure depicted in **Figure 8**. Engineers should investigate potential transfers as a routine part of their practice and incorporate appropriate design measures where required.*

5.3 Diaphragm Stiffness Modeling

ACI 318 permits the use of any set of reasonable and consistent assumptions for the stiffness of structural members. For cast-in-place concrete diaphragms, a common practice is to model the diaphragm as having infinite in-plane rigidity. ASCE 7 permits this rigid modeling assumption provided the diaphragm span-to-depth ratio is 3 or less and provided there are no horizontal irregularities as defined in ASCE 7 Table 12.3-1. In all other cases, ASCE 7 requires the structural analysis to explicitly model the flexibility of the diaphragm.

Diaphragms with a large span-to-depth ratio can develop in-plane deformations that affect design displacements and internal force distributions (**Figure 11**). Such effects are

commonly important in parking structures, where diaphragms may be split to form ramps, resulting in large span-to-depth ratios.

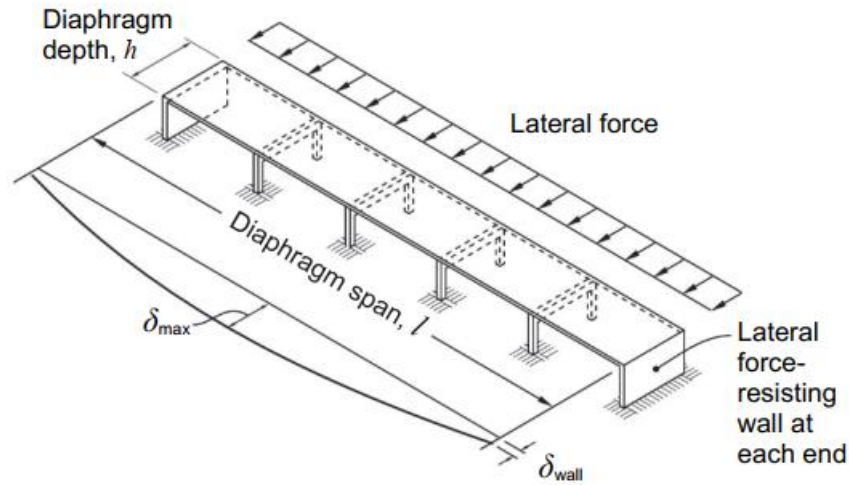

Figure 11. Effect of diaphragm deformations on distribution of displacements and forces

Buildings with offsets or discontinuities of the vertical elements of the seismic force-resisting system may develop large transfer forces at the levels of those discontinuities (**Figure 9**). If the diaphragm is modeled as a rigid element in a computer analysis of the building, unrealistically large transfer forces might be calculated at the levels of discontinuities. At such locations, and sometimes for one or several floors adjacent to the discontinuity, modeling diaphragm flexibility can produce more realistic estimates of design forces in the diaphragms and the vertical elements.

Stiffness reduction associated with diaphragm cracking is commonly approximated by applying a stiffness modifier to the diaphragm in-plane gross-section stiffness properties. Stiffness modifiers for reinforced concrete diaphragms commonly fall in the range of 0.15 to 0.50 when analyzing a building for design-level earthquake demands (Nakaki 2000). In cases where the analysis results are sensitive to diaphragm stiffness assumptions, it may be prudent to bind the solution by analyzing the structure using both the lower and upper range of diaphragm stiffnesses and selecting the design values as the larger forces from the two analyses.

5.4 Special Conditions

5.4.1 Diaphragms with Openings

For a diaphragm with small openings (on the order of a few diaphragm thicknesses for typical diaphragms), common practice is to place reinforcement on either side of the openings having area equal to the area of reinforcement disrupted by the openings, with no other special analysis. For larger openings, the diaphragm must be designed to transfer the forces around the openings. Methods used to determine these forces range from simplified hand calculations as described in Section 6 to detailed finite element modeling.

In some cases, portions of the diaphragm experience axial stresses because of global behavior or because of local actions that occur around openings. If large axial stresses develop, then confinement reinforcement may be required as discussed in Section 7.

5.4.2 Ramps

Ramps and sloping diaphragms can create unique design challenges, especially where they create a connection between different stories of a structure. In some cases, story shear can migrate out of the vertical elements of the seismic force-resisting system through the ramp in the form of shear or axial forces. This additional force in the ramp should be considered in the design of sloping diaphragms. Engineering practice varies with respect to how to treat these conditions in an analysis model. Idealizing a sloping diaphragm as a flat, continuous element might not correctly identify such forces and might lead to overstating the stiffness of the diaphragm at a particular location. The potential implications of the modeling assumptions of ramps should be considered when determining whether or not to explicitly include sloping diaphragms in an analysis model. For additional guidance, see SEAOC (2009).

Ramps

Ramps that connect to multiple levels of a structure transfer lateral forces between the connected levels and can create unique design issues including the following:

- *For seismic forces parallel to a ramp, the ramp acts as a strut between levels. For seismic forces perpendicular to a ramp, it acts as an inclined shear wall. In both cases, the force distribution to the vertical elements can be inappropriately affected.*
- *Short columns can be formed along the edges of a ramp, resulting in large shear forces in the columns that must be addressed.*
- *Ramps may split a diaphragm, which may result in a diaphragm with large aspect ratio.*

- *Where ramps terminate at a rigid foundation, lateral forces can migrate through the ramp to the foundation, thereby bypassing the intended vertical lateral system.*
- *Corkscrew ramp configurations sometimes cause an undesirable overall torsional response of the structure.*

5.5 Displacement Compatibility for Flexible Diaphragms

Flexible diaphragms will experience in-plane displacements because of inertial loading in addition to the drift experienced by the vertical elements of the seismic force-resisting system (**Figure 11**). This is addressed in ASCE 7 §12.3. Components not designated as part of the seismic force-resisting system, such as gravity beams and columns, walls bending out-of-plane, slab-column and slab-wall connections, and cladding attachments, should be evaluated for displacement compatibility based on the additional displacement of the diaphragm. In some cases, it may be appropriate to include critical elements of the gravity system in the building lateral model to explicitly evaluate forces developed due to displacement compatibility.

Historical Perspective on Diaphragm Design

Prior to structural analysis software making finite element analysis of diaphragms readily available, diaphragm design was based on the simplifying assumption that the diaphragm was either completely flexible or infinitely rigid.

Flexible diaphragms were assumed to act as simply supported beams spanning horizontally between the vertical elements of the seismic force-resisting system without consideration of continuity across interior lines of resisting elements. Diaphragm chord forces were calculated by dividing the simple span moment by the diaphragm depth. Forces “tributary” to the vertical elements were calculated as the sum of the simple span reactions to those elements.

With the rigid diaphragm assumption, distribution of lateral forces to the vertical elements was made based on their relative stiffness. This assumption was adopted in the first-generation structural analysis programs to reduce the computational demand on memory and processor speed. The lateral forces calculated for the vertical members at each line could then be translated into shear forces to be distributed along the diaphragm at each line.

In some cases, depending on the diaphragm material, overall proportions, and relative stiffness of vertical and horizontal elements, it was unclear whether to assume flexible or rigid behavior. In such cases, considering results from both flexible and rigid analyses, designers often “enveloped” the analysis.

With currently available structural analysis software, flexibility of the diaphragm can be modeled directly wherever diaphragm flexibility is in question. Bounding analyses is still valuable to understand the effects of uncertain stiffnesses on design quantities.

6. Diaphragm Analysis Guidance

6.1 Diaphragm Modeling and Analysis Approaches

Internal forces in a diaphragm are calculated using approaches that range from simple idealizations to complex computer analysis. The analysis need only be as complex as necessary to represent how lateral forces flow through the building, including the diaphragms. For regular buildings in which lateral resistance is provided by similar vertical elements distributed throughout the floor plan, simple models are often adequate for determining the diaphragm forces. For buildings with irregularities or with dissimilar vertical elements, more complex models may be required to determine the diaphragm design forces. Regardless of the idealization that is selected, the analysis method is required to satisfy requirements of equilibrium, and the design is required to provide design strengths at least equal to required strengths for all elements in the load path.

Traditional Models versus Computer Analysis

The equivalent beam, equivalent beam-on-springs, and corrected equivalent beam models (discussed in Section 6.2) are traditional, approximate approaches that are still used extensively to design concrete diaphragms. They can be especially suitable for diaphragms in regions of low and moderate seismicity because force demands typically are low relative to the inherent strength, such that more precise computation is unwarranted. In regions of high seismicity, where seismic demands commonly exceed inherent strength, computer analysis to determine diaphragm demands is increasingly common.

ACI 318 §12.5.1.3 identifies four acceptable approaches for diaphragm modeling and analysis:

- 1) **Beam model.** A diaphragm can be modeled as a beam whose depth is equal to the full diaphragm depth, using methods such as those described in Section 6.2.
- 2) **Strut-and-tie model.** A diaphragm or diaphragm segment can be modeled as a strut-and-tie system, as described in Section 6.3.
- 3) **Finite element model.** A diaphragm can be idealized with a finite-element model, as described in Section 6.4.
- 4) **Alternative models.** A diaphragm may be designed by any alternative method, provided that it satisfies the requirements of equilibrium and provides design strengths at least equal to the required strengths for all elements in the load path. Section 6.5 and Section 6.6, discuss design for large openings and design using partial-depth collectors, and provide examples of alternative models.

6.2 Beam Models

Beam models represent a diaphragm as a beam on rigid or flexible supports. Analysis involves determination of (1) internal moments, shears, and reactions and (2) the determination of resulting internal forces. These are models are discussed in Section 6.2.1 and Section 6.2.2, respectively.

6.2.1 Analysis of Moments, Shears, and Reactions

Three versions of beam models are widely used, specifically the basic equivalent beam model, the equivalent beam-on-springs model, and the corrected equivalent beam model. The models described in the following paragraphs are appropriate for levels that are not major transfer levels, such that the main role of the diaphragm is to transfer lateral inertial loads among vertical elements at a level. At a main transfer level, such as a podium where forces are transferring from one set of vertical elements to another set through the diaphragm, the beam models need to be adjusted to represent this behavior.

Basic equivalent beam model. This model treats the diaphragm as a horizontal beam spanning between idealized rigid supports, such as shown in **Figure 3**. The rigid supports represent vertical elements, such as shear walls. For the case shown, the beam is simply supported, because the walls are at the far ends of the diaphragm. This approach may also be used with the walls located inboard of the diaphragm edges, in which case the equivalent beam cantilevers beyond the supports.

Shear and moment diagrams are established by treating the diaphragm as if it were a beam. **Figure 3b** shows the shear and moment diagrams for the case with walls at the far ends of the diaphragm.

Equivalent beam-on-springs model. The equivalent beam-on-springs model envisions the diaphragm as a beam supported by flexible supports (**Figure 12**). It is most suitable in single-story buildings where spring stiffnesses are readily determined. In multi-story buildings, where force transfers are more likely and where spring stiffnesses are indeterminate, the approach can be used by applying design forces to a computer model of the entire building. One approach is to apply the diaphragm design force (**Figure 7d**) to an individual level being designed while applying the lateral forces for vertical element design (**Figure 7c**) to all the other levels. The diaphragm may be treated as a rigid beam, as a beam with flexural and shear stiffness properties, or as a plate element with in-plane stiffness properties.

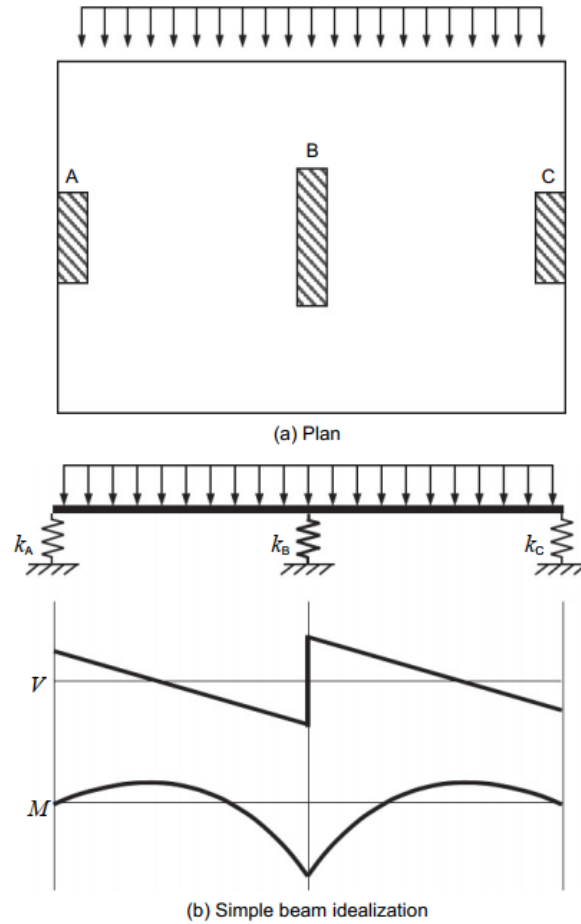

Figure 12. Equivalent beam-on-springs model

Corrected equivalent beam model. The corrected equivalent beam model can be useful for approximating diaphragm actions where there are strong interactions among vertical elements of the seismic force-resisting system. Such effects may occur where vertical elements of different stiffness interact or where building torsion or vertical irregularities occur. The basic approach is to identify the forces transferred between the diaphragm and each of the vertical elements, define a diaphragm lateral loading that is in equilibrium with these forces, and then analyze the diaphragm for this lateral loading. Where diaphragm flexibility is modeled in a computer analysis, the forces transferred to the diaphragm at a vertical element can be obtained by a section cut through the diaphragm around the vertical element. Where the diaphragm is modeled as rigid, the forces transferred to the diaphragm can be calculated as the difference in forces in the vertical element above and below the diaphragm (**Figure 10**).

For smaller buildings without irregularities and with effectively rigid diaphragms, the reactions may be determined using the direct inertial force, F_x (or F_{px}), acting through the center of mass and accounting for torsion resulting from differences in the center of rigidity and the center of mass. Referring to **Figure 13**, the diaphragm forces to the vertical elements are calculated as follows:

$$R_i = F_z \frac{k_{iz}}{\sum k_{iz}} \pm F_z e_y \frac{e_i k_i}{J_r}$$

Where:

R_i is the force acting between the diaphragm and vertical element i ;

F_z is the story force, either F_x or F_{px} , acting parallel to the z axis;

k_{iz} is the stiffness of vertical element i in the z direction for those elements having stiffness in the z direction;

e_y is the distance between the center of rigidity and the center of mass measured in the y direction;

e_i is the perpendicular distance between the center of rigidity and the stiffness k_i of vertical element i ;

J_r is the polar moment of inertia calculated as follows:

$$J_r = \sum e_i^2 k_i$$

To approximate the actions within the diaphragm, the forces R_i acting between the diaphragm and the vertical elements in the direction under consideration are summed (in **Figure 13**, this would be $R_A + R_B = F_x$) and their centroid is determined. For a rectangular diaphragm of uniform mass, a trapezoidal distributed force having the same total force and centroid is then applied to the diaphragm. The resulting shears and moments (**Figure 13 b**) are acceptable for diaphragm design. This approach leaves any moment due to R_C and R_D unresolved; sometimes this issue is ignored or, alternatively, it can be incorporated into the trapezoidal loading as well.

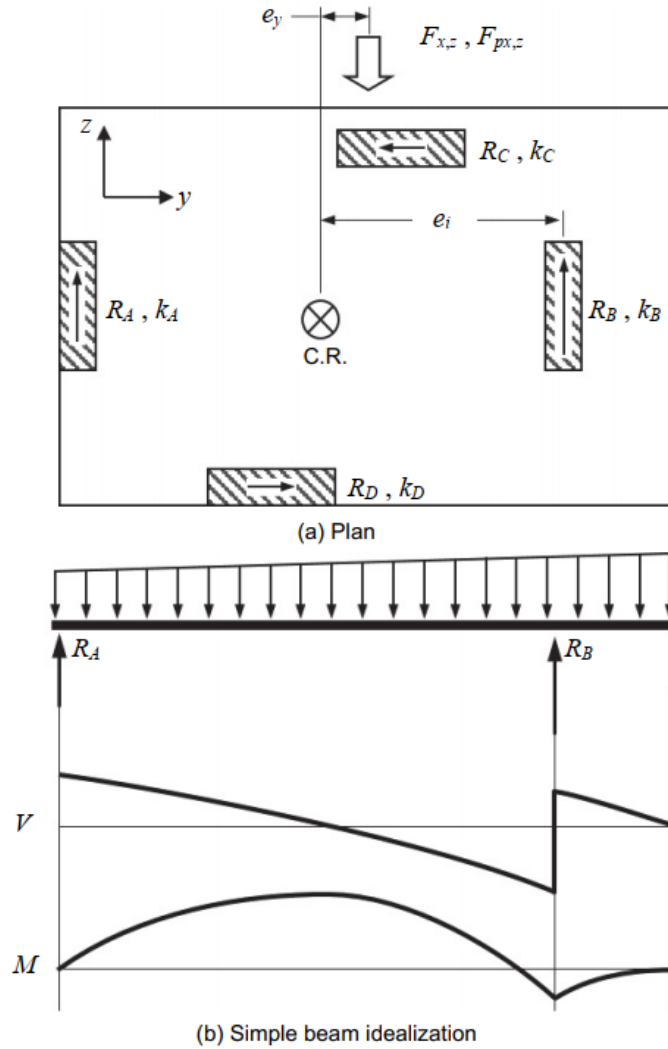

Figure 13. Corrected equivalent beam model

6.2.2 Internal Forces in Beam Models

Where beam models are used, internal diaphragm forces are idealized in terms of in-plane moment, in-plane shear, and tension and compression in collectors. **Figure 3** and **Figure 4** illustrate the idealizations for a solid diaphragm.

As shown in **Figure 3**, diaphragm in-plane moment is resisted through a tension-compression couple formed by tension and compression chords located along opposite outer

edges of the diaphragm. The tension and compression chord forces, T_u and C_u , respectively, are calculated as:

$$T_u = C_u = M_u / jd$$

It is not uncommon to take $jd = d$ or $jd \approx h$ where chords are located near the diaphragm edge. Reinforcement to resist the force T_u is usually placed near the outer edges of the diaphragm, although other options are sometimes followed as shown in Section 7.

Where chords are designed at the outer edges of the diaphragm, equilibrium requires that the in-plane shear stress be uniform across the depth of the diaphragm (**Figure 3**). ACI 318 writes diaphragm shear strength in terms of A_{cv} , which is the product of the diaphragm slab thickness t and total depth h of the diaphragm. Therefore, it is reasonable to write the shear stress as:

$$v_u = V_u / A_{cv}$$

The existence of uniform shear stress along the diaphragm depth requires that collectors be provided along the full diaphragm depth to “collect” the shear stresses. See **Figure 4** for the case of a collector having a width equal to the width of the vertical element.

It is also permitted for the collector to be wider than the width of the vertical element, such that only part of the collector force is transferred directly into the boundary of the vertical element, with the rest being transferred through shear-friction along the length of the vertical element (**Figure 14**). In this case, the collector is defined to include the compression portion (Point a to Point b), the tension portion (Point c to Point d), and the shear transfer portion along the length of the wall (Point b to Point c). In this example, part of the collector compression (C_D) is transferred directly into the boundary, with the remainder (C_v) being transferred through shear along the length of the vertical element. Similar conditions apply to the tension forces.

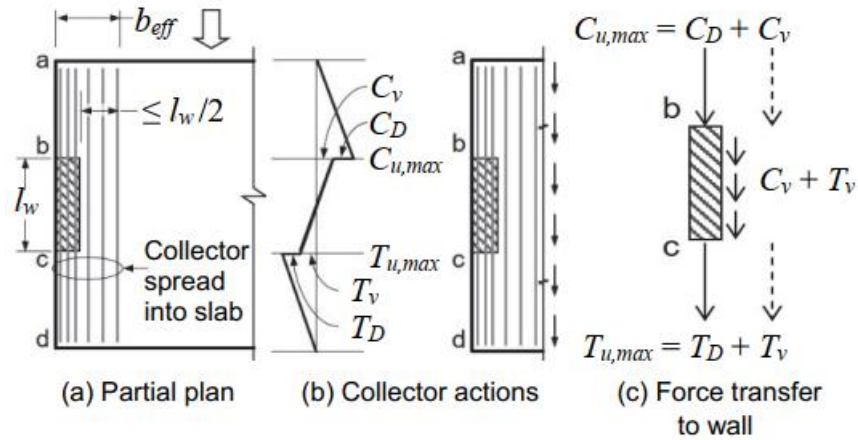

Figure 14. Force transfer where a collector is wider than the vertical element to which it transmits diaphragm shears.

There are no building code requirements governing the effective width b_{eff} of a collector (**Figure 14**). *Using a Concrete Slab as a Seismic Collector* (SEAOC 2005) suggests b_{eff} of the collector should not exceed the vertical element width plus a width on either side of the vertical element equal to half the contact length between the diaphragm and the vertical element. Eccentric collectors result in moments about the vertical element that must be considered in the design.

6.3 Strut-and-Tie Models

Strut-and-tie models can be used to idealize the flow of force through a diaphragm in a way that satisfies equilibrium. Such models have not been used extensively for the overall design of diaphragms, although sometimes they can be useful for this purpose. Strut-and-tie models are more often used to identify force paths and reinforcement layouts around discontinuities. Where used, this Guide recommends that distributed reinforcement of at least 0.0025 times the gross slab area be provided in each direction to control cracking.

Figure 15 illustrates how strut-and-tie models can be used to understand required reinforcement layouts. In this example, force from a structural wall is transferred around an opening through a collector, into a diaphragm, and into nearby basement walls. The force transfer in the diaphragm can be visualized as occurring through compression struts acting at an angle between about 30° and 60° relative to the wall force. Considering the zone bounded by Point a, Point b, Point c, and Point d as a free body diagram, moment equilibrium about Point d requires a tension tie between Point b and Point c, which must be developed into the adjacent

diaphragm segment. Moment equilibrium about Point c cannot be provided by a tension tie from Point a to Point d because the tension tie would have to be anchored to the basement wall, which is typically not designed for an out of plane force generated by a tension tie. Instead, moment equilibrium about Point c is provided by a compressive force from the adjacent diaphragm segment at Point a. Force reversal as occurs during earthquakes would reverse the diagonal compression struts and require a tension tie between Point a and Point d Point a tension tie between Point e and Point h (not shown). Section 7 provides additional discussion on how to detail the required reinforcement.

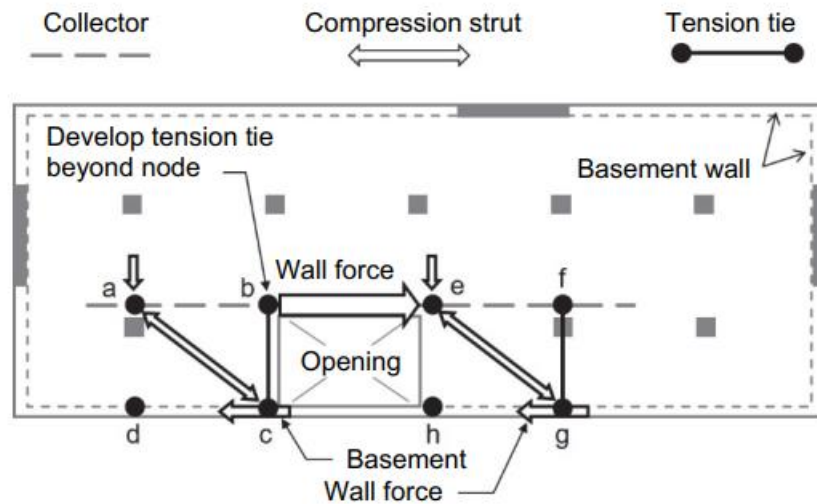

Figure 15. Strut-and-tie model at force transfer to basement wall

Excessive openings in podium diaphragms can create challenging design conditions. Consider the idealized example in Figure 16. If the wall along axis B must transfer a large force through the podium diaphragm to the basement wall, the only suitable path might be through a long collector between Point a and Point b. If collector bars are cut as the collector force decreases along the length, the elongation of the collector would be approximately the yield strain times the length between Point a and Point b. If the collector is fixed at Point b, then Point a must move an amount equal to the elongation, possibly resulting in excessive shear deformation of the panel with corners at Point c, Point d, Point f, and Point e. Alternatively, if the diaphragm deforms excessively because of a long collector, the wall shear force is likely to find an alternative load path through the shear wall down to the level below the podium slab. Another example occurs for the wall along axis D. The strut-and-tie solution satisfies statics, but the long load path involves movement of the wall that would be incompatible with the

connection at Point j. Fewer openings in a podium slab would be preferred and should be sought early in the design.

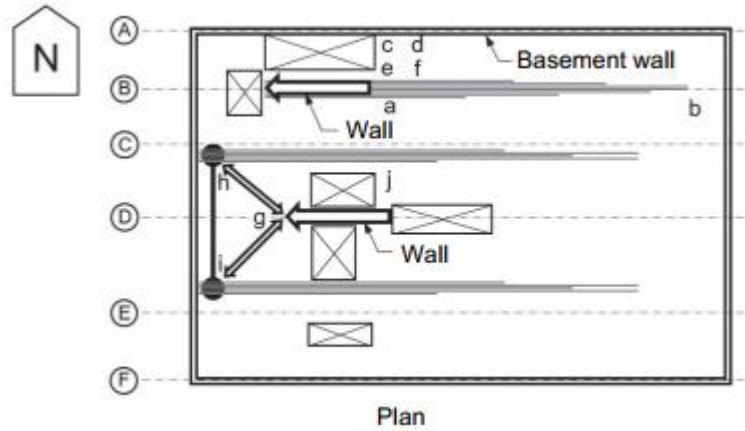

Figure 16. Challenging design conditions

6.4 Finite Element Models

Finite element modeling of a diaphragm can be useful for identifying the load paths in diaphragms with large openings or other irregularities, modeling the stiffness of ramps in parking garages, and assessing the force transfers among vertical elements of the seismic force resisting system. Figure 17 shows an example of an irregularly-shaped diaphragm that may warrant use of finite element modeling. Figure 9 illustrates a building with vertical irregularities, because of setbacks and podium transfers, that likely warrants modeling diaphragm flexibility for levels adjacent to the irregularities.

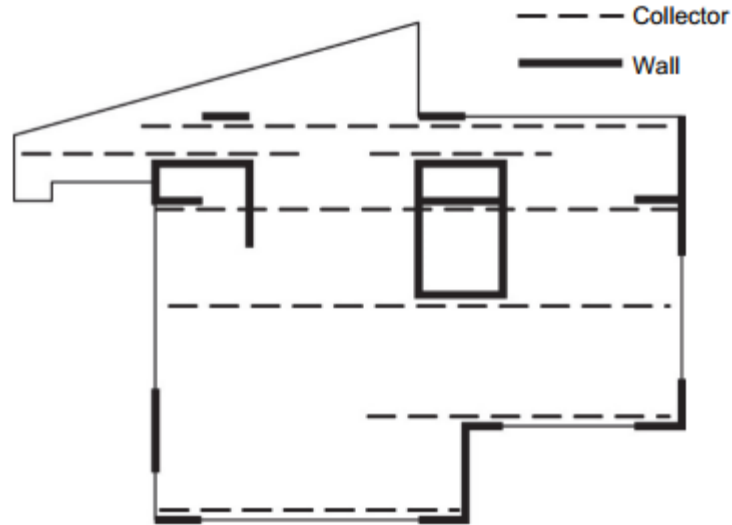

Figure 17. Irregularly shaped diaphragm

To adequately model the diaphragm flexibility, finite element meshing typically needs to be $1/5$ to $1/3$ of the bay length or wall length, although a finer mesh sometimes is beneficial. If section cuts are made through the diaphragm model to determine the shear distribution within the diaphragm, the finite element mesh at and near the section cut should be moderately fine.

In subterranean levels, diaphragm forces can migrate from the diaphragm into the basement walls, as may occur, for example, where the basement walls act as the flanges for diaphragm in-plane moment resistance. In such cases, section cuts need to extend through the basement walls such that the basement wall forces are not missed in the structural system design.

6.5 Diaphragms with Large Openings

Design of a diaphragm with a large opening is analogous to design of a beam with an opening. Consider the opening shown in Figure 18. One approach is to assume that the reinforcement labeled L collects the uniform diaphragm shear that acts to the left of the opening and drags it to the portions of the diaphragm above and below the opening in proportion with their relative stiffnesses. The reinforcement labeled R then collects the shear from above and below the opening and drags it to the portion of the diaphragm to the right of the opening. The reinforcement labeled T and B resists the local moment within the section above and below the opening. This moment is sometimes approximated as $V_T (l/2)$ and $V_B (l/2)$, which is correct if the inflection point is at the center of the length of the opening. The

inflection point may vary, which will increase the moment. If a finite element analysis is being used, section cuts can be used to determine the forces, and a hand analysis approach such as the one described here can be used as a tool to check the results.

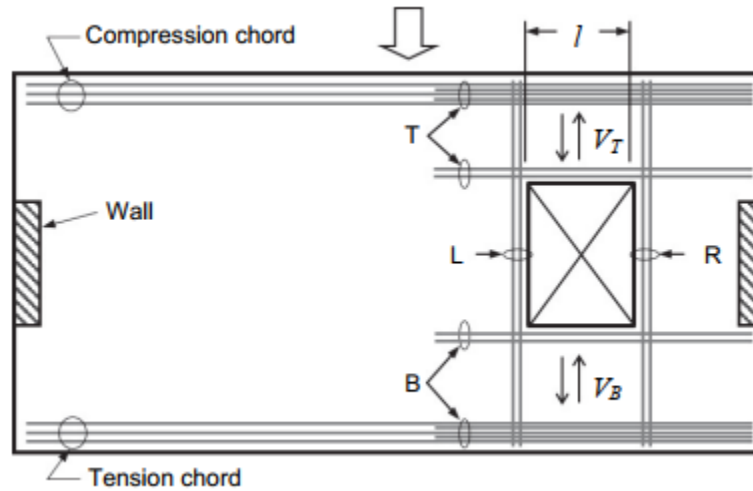

Figure 18. Diaphragms with large openings.

6.6 Partial-Depth Collectors

An alternative design procedure is to determine the minimum length of the vertical element plus collector required for transferring shear to the vertical element, and then provide a collector, if required, along this length. For example, in Figure 19, the required length considering diaphragm shear strength is l_{ac} , and the corresponding partial-depth collector extends along that length. Where the upper limit on diaphragm shear strength is used, this approach minimizes both the collector area and length. In some cases, all of the force might theoretically be transferred directly to the vertical element without a collector, but we recommend extending a collector at least a bay width or 25 feet (7.6 m) into the diaphragm, whichever is longer, to control cracking near the ends of the wall. The design force in the collector should vary linearly from zero at the end of the collector to a maximum at the face of the vertical element.

Design of partial-depth collectors requires additional considerations. A load path must be established for inertial forces in all areas of the diaphragm to reach the concentrated area of higher shear adjacent to the vertical elements and partial-depth collectors. In this regard, the load path is similar to a dapped or notched beam for which a concentration of reinforcement is required at the edge of the full-depth section that collects the shear and transfers it to the

reduced depth section at the end of the beam. For the diaphragm, the load path requires a secondary distributed collector adjacent to the partial depth collector. Typical, distributed slab reinforcement parallel to the vertical element serves as this secondary collector. Where necessary, the area of distributed slab reinforcement is increased locally to deliver shear forces from the lower shear section to the higher shear region. The secondary collector also picks up local inertial forces from the area with corners at Point c, Point d, Point g, and Point f and from the small area to the left of it.

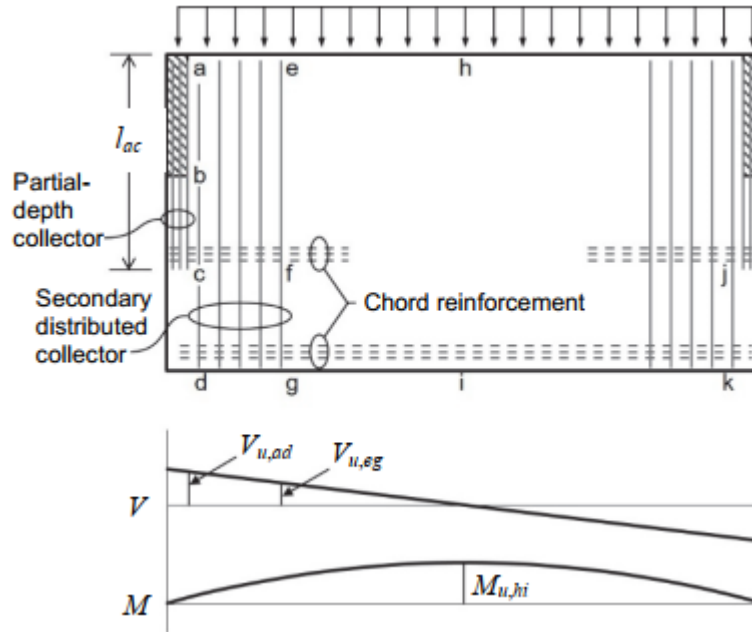

Figure 19. Partial-depth collector

For the partial-depth collector shown in Figure 19, the following design considerations apply. Near the diaphragm mid-span, the full depth of the diaphragm is used to resist diaphragm moment and shear. Thus, at mid-span the required chord tension force is $T_u = M_{u,hi} / jd$, where jd refers to diaphragm depth between Point h and Point i. Along the line from Point e to Point g, the full depth diaphragm must be sufficient to transfer a uniform shear stress of $v = V_{u,eg} / A_{cv}$. The secondary collector reinforcement must be sufficient to transmit in tension the shear acting along the line from Point f to Point g plus additional diaphragm inertial forces in the region with corners at Point c, Point d, Point g, and Point f. Along the line from Point a to Point c, the diaphragm reinforcement must be sufficient to transfer $V_{u,ac}$ as uniformly distributed shear. Partial-depth collector reinforcement along the line from Point b to Point c

must be sufficient to carry the shear picked up along the line from Point b to Point c. And finally, chord reinforcement along the line from Point c to Point f must be capable of resisting the diaphragm moments along that length assuming the effective depth of the diaphragm is reduced to the length of the line between Point e and Point f. If the secondary distributed collector was not included in the design, the effective depth of the diaphragm for all moment calculations would be reduced to the length of the line between Point e and Point f, requiring larger area of chord reinforcement placed entirely along the line from Point c to Point j, and distributed steel would still be required in the region with corners at Point c, Point d, Point g, and Point f to transmit inertial loads developed in that region to the shallower effective beam of depth from Point e to Point f. Treating the diaphragm as a shallower beam of depth from Point e to Point f also could result in large cracks forming at the extreme tension edge of the diaphragm as it is flexed under lateral load. See Sabelli et al. (2009a; 2009b) for additional discussion of partial-depth collectors.

6.7 Diaphragm Shear Distribution

A design should ensure that the shear stress distribution in a diaphragm is in equilibrium with the internal moment resistance. For example, where in-plane moment is resisted by chords located at the outer boundaries of the diaphragm, concepts of shear flow require that the shear stress distribution be constant through the diaphragm depth (Figure 3). A partial-depth collector design, as illustrated in Figure 19, resists non-uniform shear stress through a combination of secondary collectors and chords that provides a complete load path. A design that resists moment through reinforcement that is uniformly distributed through the diaphragm depth would resist diaphragm shear that is zero at the outer tension face and increases linearly to a maximum value of approximately $2V_u/A_{cv}$ near the compression side.

6.8 Diaphragm-to-Vertical-Element Force Transfer

Diaphragm shear is transferred to vertical elements by the collectors and by shear-friction between the diaphragm and the vertical element. Where collector bars enter a vertical element, such as a wall, the force is transferred directly to the wall. However, the collector may need to extend into the vertical element a distance that is much longer than a collector bar development length. Figure 20 illustrates the case where a tension collector enters one side of a wall.

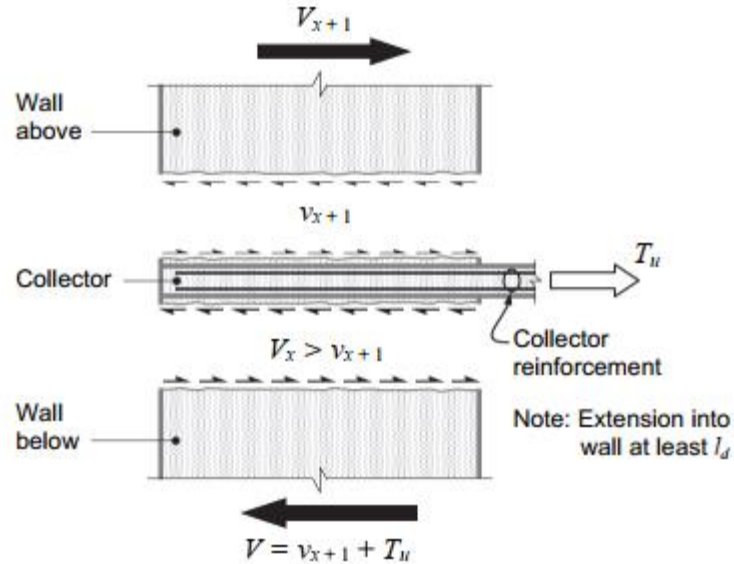

Figure 20. collector force directly to shear wall

The shear V_{x+1} in the wall segment above the diaphragm is normally considered to produce uniform shear flow v_{x+1} across the wall width. The shear V_x in the wall segment below the diaphragm is increased by the force T_u transferred from the collector. To achieve uniform shear flow v_x across the lower wall segment, at least some of the collector steel must extend along the full wall length. Alternatively, the collector reinforcement can be lap-spliced with added wall reinforcement that drags the force toward the far side of the wall. In the case where a compression collector frames into the left side of the wall, with a tension collector on the right side, the tension collector reinforcement need not extend full length, as only a portion of the force that transfers to the wall is provided by the tension collector. Collectors that extend through the entire length of a vertical element ensure that force is transferred from the collector to the element without further consideration.

6.9 Diaphragm Slabs on Ground

Although slabs bearing on ground develop inertial forces, conventional practice is to assume that these forces are resisted by the ground and can be otherwise ignored. For some structures, however, slabs bearing on ground are used as diaphragms to tie together and distribute forces among connected vertical elements and foundation elements. This is done where the foundation supporting a vertical element does not have adequate soil friction and passive bearing strength to resist design horizontal load on its own. The slab on ground

diaphragm redistributes some of the horizontal load to locations where additional resistance to sliding is obtained. Friction below the slab-on-ground diaphragm and below other foundation elements, as well as the passive bearing acting on these other foundation elements, provide the added resistance to sliding.

Slabs on ground that serve as diaphragms are considered structural slabs. Structural slabs are required to be designed in accordance with ACI 318. Although these slabs typically do not need to be reinforced for flexure caused by loads on the surface of the slab, they must be reinforced for the in-plane shear and moment. These slabs must also meet the minimum reinforcement requirements for a structural slab.

7. Design Guidance

7.1 Load and Strength Reduction Factors

Strength Design Method

ACI 318 uses the strength design method to provide the intended level of safety. The basic requirement for strength design can be expressed as design strength \geq required strength. The design strength is written in the general form ϕS_n , in which ϕ is a strength reduction factor and S_n is the nominal strength. The required strength is expressed in terms of factored loads, or related internal moments and forces. The strength design method is essentially the same as the Load and Resistance Factor Method (LRFD) used for the design of some other materials.

Chapter 2 of ASCE 7 defines the load combinations applicable to diaphragm and collector design. The load combinations require consideration of horizontal seismic effects, vertical seismic effects, dead load, live load, and other loads such as soil pressures, snow, fluid, and other applicable loads. ASCE 7 §12.4.2 defines the horizontal seismic effect as $E_h = \rho Q_E$ and the vertical seismic effect as $E_v = 0.2S_{DS}D$. In these expressions, ρ is the redundancy factor, Q_E is the effect of horizontal seismic forces, S_{DS} is the design spectral response acceleration parameter at short periods, and D is the effect of dead load. In general, E_h and E_v must be applied in all combinations in both positive and negative directions.

The basic seismic load combinations are:

$$\begin{aligned} &1.2D + E_v \pm E_h + L + 0.2S \\ &0.9D - E_v \pm E_h \end{aligned} \quad (\text{ASCE 7-10 §2.3.6})$$

Where the over strength factor is required to be used, the seismic load combinations are:

$$\begin{aligned} 1.2D + E_v \pm E_{mh} + L + 0.2S \\ 0.9D - E_v \pm E_{mh} \end{aligned} \quad (\text{ASCE 7-10 §2.3.6})$$

In these expressions, $E_{mh} = \Omega_o Q_E$, that is, the effect of horizontal seismic forces including over strength factor Ω_o . The load factor on L is permitted to equal 0.5 for all occupancies in which unreduced design live load is less than or equal to 100 psf (4.79 kN/m²), with the exception of garages or areas occupied as places of public assembly.

In general, diaphragms and collectors are permitted to be designed for seismic forces applied independently in each of the two orthogonal directions. For structures assigned to Seismic Design Category C, D, E, or F and having nonparallel systems (plan irregularity Type 5 per ASCE 7-16 Table 12.3-1), however, diaphragm design must consider the interaction of orthogonal loading in one of two ways. If the Equivalent Lateral Force Procedure or Modal Response Spectrum Analysis is used, 100 percent of the effects in one primary direction are to be combined with 30 percent of the effects in the other direction. If a response-history analysis is performed in accordance with ASCE 7 §16.1 or ASCE 7 §16.2, orthogonal pairs of ground motion histories are to be applied simultaneously.

Governing Load Combinations

The load combinations specified in IBC §1605 are based on the load combinations from ASCE 7 Chapter 2. However, the IBC factors on snow load are different from those in ASCE 7. Where there is a discrepancy between the two documents and the IBC is the governing code, the IBC load combinations take precedence.

Although not required by ASCE 7, common practice is to consider the orthogonal combination for all diaphragm and collector design. This Guide adopts that approach.

Where beam models are used, design for moment or moment combined with axial force can be done using a tension-compression couple, with strength reduction factor $\phi = 0.9$.

For diaphragm shear, the basic strength reduction factor is $\phi = 0.75$. However, for structures that resist the earthquake effects using intermediate precast structural walls in Seismic Design Category D, E, or F, or special moment frames or special structural walls in any Seismic Design Category, the strength reduction factor for diaphragm shear is $\phi = 0.6$ if the nominal diaphragm shear strength is less than the shear corresponding to the diaphragm

moment strength. In addition, the strength reduction factor for diaphragm shear may not exceed the minimum strength reduction factor for shear used for the vertical components of the seismic force-resisting system. Consequently, for most designs, the strength reduction factor for diaphragm shear is $\phi = 0.6$.

For tension members, such as collectors in tension, $\phi = 0.9$.

For compression members, such as collectors or struts around openings in compression, $\phi = 0.65$, except $\phi = 0.75$ in the unusual case that the compression member is designed as a spiral reinforced column.

7.2 Tension and Compression Chords

Where simple beam models are used, ACI 318 §12.5.2.3 requires that non-prestressed reinforcement resisting tension due to moment be located within $h/4$ of the tension edge of the diaphragm, where h = diaphragm depth measured in the plane of the diaphragm at that location. Where the diaphragm depth changes along the length of the diaphragm span, it is permitted to develop reinforcement into adjacent diaphragm segments that are not within the $h/4$ limit. Figure 21 illustrates these requirements. See additional discussion in Section 7.5.2. There are no restrictions on placement of prestressed reinforcement provided to resist moment through precompression.

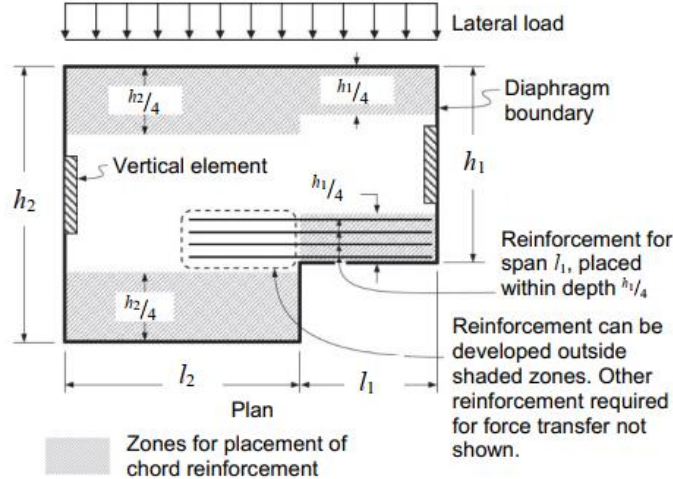

Figure 21. Locations of non-prestressed reinforcement resisting

Section 6.2.2 described the calculation of chord forces when simplified beam models are used to approximate the diaphragm internal forces. Where non-prestressed reinforcement is concentrated near the edge of the diaphragm, the equation for the reinforcement area of the tension chord, using $\phi = 0.9$, is:

$$A_s = \frac{T_u}{\phi f_y}$$

Typically, the chord reinforcement is placed within the middle third of the slab or beam thickness, so as to minimize interference with slab or beam longitudinal reinforcement and to reduce contributions to slab and beam flexural strength.

Where chord reinforcement is positioned within a beam, the chord and the beam typically are oriented to resist orthogonal effects, such that the same reinforcing bars can resist moment for loading in one direction and chord tension for loading in the orthogonal direction. Where orthogonal effects are combined using the 100%–30% combination rule per ASCE 7 §12.5.3(a), such that the longitudinal reinforcement is the larger of that required to resist (a) $1.0X + 0.3Y$ and (b) $0.3X + 1.0Y$. In most cases, if the beam is part of a special moment frame, the required longitudinal reinforcement will be sufficient for chord requirements.

Bonded tendons may be used as reinforcement to resist collector forces, diaphragm shear, or diaphragm flexural tension, but they must be proportioned such that the stress due to design earthquake forces does not exceed 60,000 psi (420 MPa). Unbonded, unstressed tendons are not permitted to resist collector, shear, or moment forces because of concerns about the development of wide cracks and excessive flexibility under earthquake loading. Precompression forces from unbonded tendons, however, is permitted to resist diaphragm forces, provided there is a complete seismic load path.

The use of precompression warrants added discussion. In a typical prestressed floor slab, prestressing is proportioned to resist the load combination of $1.2D + 1.6L_{red}$. For earthquake design, the gravity load to be resisted by prestressing is reduced because the governing load combination is equal to $1.2D + f_1L_{red} + E$. Therefore, the percentage of prestressing, originally provided for gravity load resistance, that is available as precompression to resist in-plane loads is:

$$\left[1 - \left(1.2 + \frac{f_1}{D / L_{red}} \right) / \left(1.2 + \frac{1.6}{D / L_{red}} \right) \right] \times 100$$

For example, if $D = 120$ psf (5.7 kN/m²), $L_{red} = 24$ psf (1.1 kN/m²) assuming $L = 40$ psf (1.9 kN/m²) and is reducible by 40 percent, $f_1 = 0.5$ for a floor live load and the minimum permitted prestress of 125 psi (0.86 MPa), the precompression stress f_{pc} available to resist earthquake effects is 14.5 psi (0.10 MPa). Higher precompression stress is available where higher prestressing is used. The preceding example assumes that only the prestressing provided for gravity load resistance is being used for diaphragm in-plane moment resistance. Of course, additional prestressing can be provided for the express purpose of resisting diaphragm moment. The diaphragm in-plane moment that can be resisted by precompression is obtained using diaphragm gross-section properties within the equation $M = f_{pc}S_m$. Additional moment, if any, must be resisted by bonded reinforcement.

The flexural compression zone usually does not require direct consideration in design and detailing. The exception is where the flexural compression force C_u due to diaphragm in-plane moment is resisted by a strut placed along an opening or other discontinuity (Figure 22).

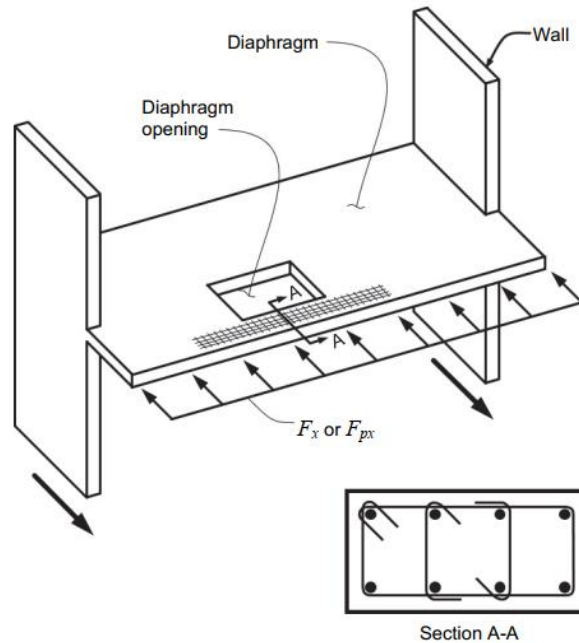

Figure 22. Confinement reinforcement in axial struts around openings.

If the calculated compressive stress on a strut exceeds $0.2f_c'$, or $0.5f_c'$ where design forces have been amplified to account for overstrength of the vertical elements of the seismic force-resisting system, confinement reinforcement is required (ACI 318 §18.12.3.2). The required confinement reinforcement, including hoops with required seismic hook dimensions, can be difficult to fit within typical slab depths and may require increased slab depth. Where required, confinement reinforcement should be continued into the slab beyond the strut at least the longer of the tension development length of the longitudinal reinforcement or 12 inches (300 mm). The same requirements also apply where diaphragm shear is carried through struts.

7.3 Diaphragm Shear

Every section of a diaphragm is to be designed to have unit design shear strength not less than the factored unit shear. For diaphragms having chord reinforcement located near the extreme flexural tension edge, the factored shear V_u is uniformly distributed. The design shear strength in this case is given by ϕV_n , where $\phi = 0.6$ or 0.75 as discussed in Section 7.1, and V_n is given by:

$$V_n = A_{cv} \left(2\lambda \sqrt{f_c'} + \rho_t f_y \right), \text{ psi} \quad (\text{ACI 318 §18.12.9.1})$$

$$V_n = A_{cv} \left(0.17\lambda \sqrt{f_c'} + \rho_t f_y \right), \text{ MPa}$$

in which uniformly distributed slab reinforcement providing ρ_t is perpendicular to the diaphragm moment reinforcement (that is, parallel to the shear force) (**Figure 23**). Where the factored shear stress varies throughout the diaphragm depth, the design unit shear strength, calculated by substituting the unit area for A_{cv} in the above equation, must exceed the factored unit shear at every section. In addition, the maximum value of V_n cannot exceed:

$$8\sqrt{f_c'} A_{cv}, \text{ psi} \quad (\text{ACI 318 §18.12.9.1})$$

$$0.67\sqrt{f_c'} A_{cv}, \text{ MPa}$$

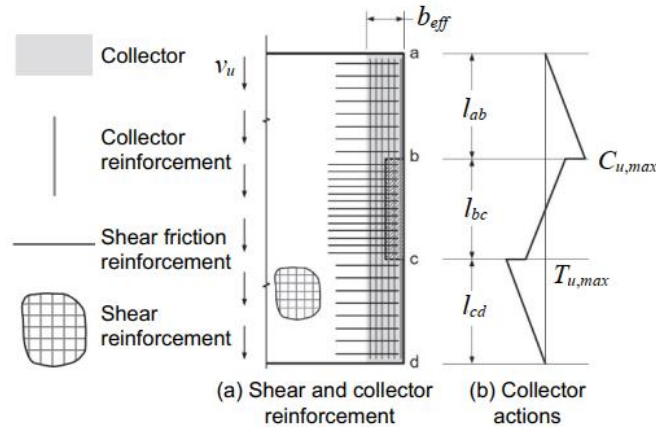

Figure 23. Shear reinforcement, collector reinforcement, and shear friction reinforcement.

ACI 318 requires shear reinforcement ρt to be provided only in the direction parallel to the applied shear. However, most typical diaphragms are relatively deep members, similar to squat walls, for which shear strength is derived from distributed reinforcement in both directions. Therefore, this Guide recommends that distributed reinforcement provided for shear be at least equal to ρt in both directions.

According to ACI 318, reinforcement provided to resist diaphragm in-plane forces shall be in addition to reinforcement designed to resist other load effects, except reinforcement designed to resist shrinkage and temperature effects shall be permitted to also resist diaphragm in-plane forces. As discussed in Section 7.2, load combinations including earthquake effect E , have lower factors on the gravity load effects. Any excess reinforcement that is not required for gravity loads under the seismic load combination can be used to resist in plane forces.

Shear reinforcement can be placed anywhere within the slab thickness within the required cover limits. Some structural engineers specify a continuous mat of bottom reinforcement that satisfies both the diaphragm shear and slab moment requirements. Where this is done, the total reinforcement area is the sum of areas required for moment and shear, considering the governing load combination.

7.4 Force Transfer between Diaphragm and Vertical Elements

Force transfer between a diaphragm and the vertical elements generally occurs through a combination of collectors (including their connections) and shear friction. Seismic design forces for collectors and their connections are determined by the design seismic forces and the

selected load path. See Section 5 for guidance on design seismic forces, including proper application of Ω_o and ρ factors. See Section 6 for guidance on load paths. Figure 23 illustrates a typical collector and its connections. Minimum cross-sectional dimensions of collectors can be determined by tension or compression limits. For the case of compression, the factored compressive force must not exceed the design compressive strength of the collector element, defined by:

$$\phi P_o = \phi \left[0.85 f'_c (A_g - A_s) + f_y A_s \right]$$

Because collectors act in tension for earthquake loading in one direction and compression for loading in the other direction, loading in compression seldom controls. For structures assigned to Seismic Design Category D, E, or F, ACI 318 §18.12.7.5 requires that collector elements have transverse confinement reinforcement if the compressive stress based on the gross cross section exceeds $0.2f'_c$ for standard load combinations and $0.5f'_c$ for load combinations with overstrength. The transverse confinement reinforcement is required until the compressive stresses are below $0.15f'_c$ and $0.4f'_c$ for standard load combinations and load combinations with overstrength, respectively. Collector cross-sectional dimensions (for example, the width and thickness of the shaded region in Figure 23) sometimes are sized to avoid triggering these requirements for transverse confinement reinforcement.

For the case of tension, the collector must be sized so that longitudinal reinforcement at splices and anchorage zones has either (a) or (b), as follows:

(a) Center-to-center bar spacing of at least three longitudinal bar diameters, but not less than 1½ inches (38 mm), and concrete clear cover of at least two and one-half longitudinal bar diameters, but not less than 2 inches (50 mm); or

(b) Transverse reinforcement providing A_v at least the greater of:

$$0.75 \sqrt{f'_c} \frac{b_w s}{f_{yt}} \text{ and } 50 \frac{b_w s}{f_{yt}}, \text{ psi}$$

$$0.062 \sqrt{f'_c} \frac{b_w s}{f_{yt}} \text{ and } 0.35 \frac{b_w s}{f_{yt}}, \text{ MPa}$$

This is intended to reduce the possibility of bar buckling and provide adequate bar development conditions in the vicinity of splices and anchorage zones. See ACI 318 §18.12.7.6 and ACI 318 §11.4.6.3.

The Confinement Trigger for Collectors

According to ACI 318, collectors must be confined wherever the nominal compressive stress exceeds $0.2fc'$ (or $0.5fc'$). The $0.2fc'$ trigger was adopted from a similar provision that traditionally was used for shear walls. The trigger was based on the idea that if the wall was designed for an effective $R = 5$, yielding in compression would be indicated if the compressive stress under design-level loads reached $(1/5)fc'$. The shift to $0.5fc'$ assumes $\Omega_o = 2.5$.

The transfer of forces between the diaphragm, collector, and vertical element of the seismic force-resisting system depends on the layout of various elements. Consider the example illustrated in Figure 23. The maximum design compressive force in collector segment ab is $C_{u,max} = \Omega_o V_{utlab}$ and the maximum design tensile force in collector segment cd is $T_{u,max} = \Omega_o V_{utlcd}$. The collector is 50 percent wider than the width of the wall it frames into; therefore, two-thirds of the collector force is transferred directly into the wall boundary, with one-third being transferred through shear-friction adjacent to the long face of the wall. Shear-friction reinforcement is required along the entire length of the collector and wall. Along lab and lcd, continuous bottom reinforcement in the diaphragm, if present, may suffice to resist the total shear forces V_{utlab} and V_{utlcd} , respectively. Along length lbc, the total design shear force is $V_{utlbc} + (T_{u,max} + C_{u,max})/3 = V_{ut}(l_{bc} + \Omega_o(l_{ab} + l_{cd})/3)$, and this force may well require more than the typical bottom mat reinforcement to achieve required strength. The apparent inconsistency in applying Ω_o to some forces and not to others, leading to section cuts that are not in equilibrium, is a recognized inconsistency, but is required by the building code.

The construction sequence determines some of the details for shear-friction design. Where a vertical element is cast to the bottom of a diaphragm, followed by casting the diaphragm and then another vertical element, cold joints exist both above and below the diaphragm (Figure 24a). In this case, shear-friction requirements must be satisfied through monolithic concrete at the face of the wall using dowels and through the two cold joints using a combination of wall reinforcement and dowels. Where a vertical element is formed ahead of casting the diaphragm, a cold joint exists at the face of the wall (Figure 24b). In this latter case, design of the dowels to resist shear through shearfriction across the cold joint becomes critical. ACI 318 §18.12.10.1 requires that all construction joints be clean, free of laitance, and also

intentionally roughened to a full amplitude of approximately 1/4 inch (6 mm). Alternatively, some engineers specify shear keys.

When designing shear-friction reinforcement, out-of plane (due to gravity loads) and in-plane (due to seismic loads) effects must be combined using the appropriate load combination. Connections between diaphragms and vertical elements of the seismic force-resisting system also must be capable of resisting forces associated with out-of-plane loading of the vertical elements. Where the Equivalent Lateral Force Procedure or Modal Response Spectrum Analysis are used, orthogonal effects are combined using the 100%–30% rule, such that only 30 percent of the out-of-plane seismic force needs to be considered concurrent with the diaphragm shear-friction transfer.

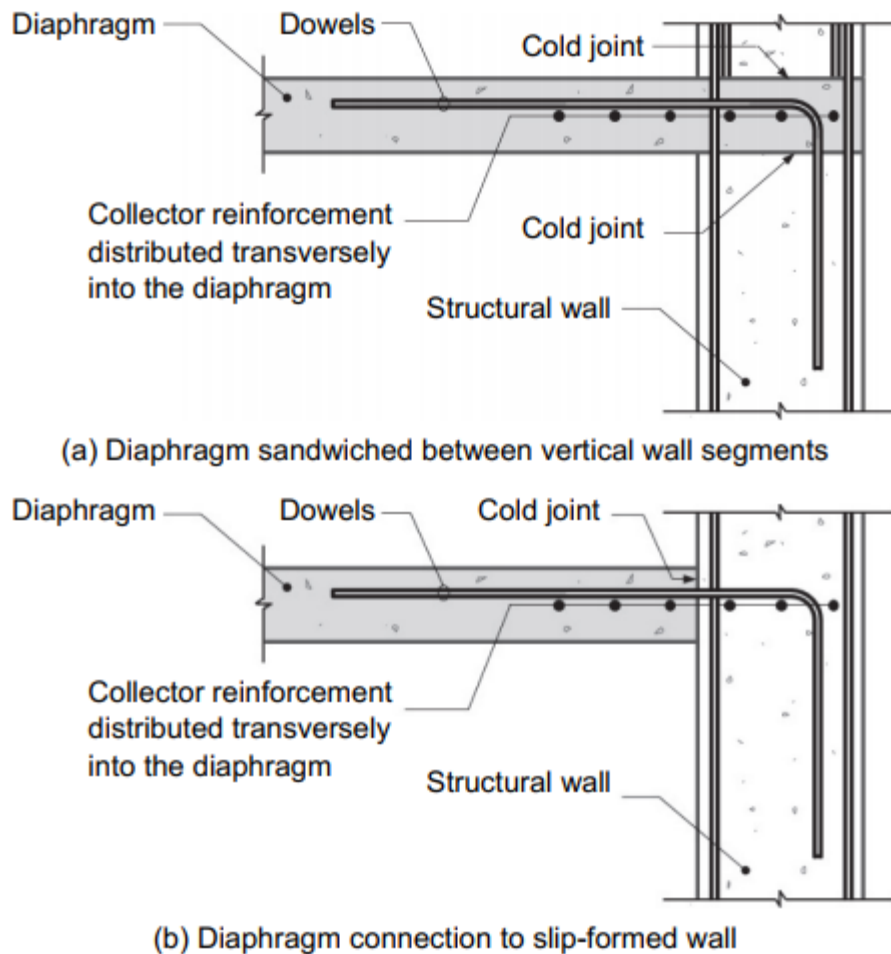

Figure 24. Shear reinforcement, collector reinforcement, and shear friction reinforcement.

7.5 Special Cases

7.5.1 Openings Adjacent to Vertical Elements

Architectural requirements sometimes dictate openings adjacent to walls that are part of the seismic force resisting system. This can create force transfer challenges, especially at podium levels where large forces may need to be transferred. The preferred approach is to work with the architect to plan locations of openings so that they do not interfere with major force transfers. Where openings in critical locations cannot be avoided, workable solutions can sometimes be designed.

Figure 15 illustrates the force transfer from a shear wall to a basement wall where the two walls are separated by a large opening in the diaphragm. Figure 25 illustrates how reinforcement might be detailed in the diaphragm segment to the left of the opening.

For the collector in tension, uniform shear flow can be assumed between the collector and diaphragm segment along the line from Point a to Point b, resulting in shear stresses acting on the diaphragm segment as shown in Figure 25b. Moment equilibrium of the segment requires equal shear stresses along the face from Point a to Point b, the face from Point b to Point c, the face from Point a to Point d, and the face from Point c to Point d. Shear reinforcement satisfying ACI 318 Eq. 18.12.9.1 is required uniformly in both directions to resist this applied shear. The basement wall also must be reinforced locally along the line from Point c to Point d for the shear applied along that length. The edge from Point b to Point c of the diaphragm segment requires a tension tie to pick up the shear stresses along that edge; that tension tie needs to be developed into the adjacent diaphragm. A compression reaction near Point a completes the equilibrium requirements. Similar but opposite action occurs for the collector in compression (Figure 25c).

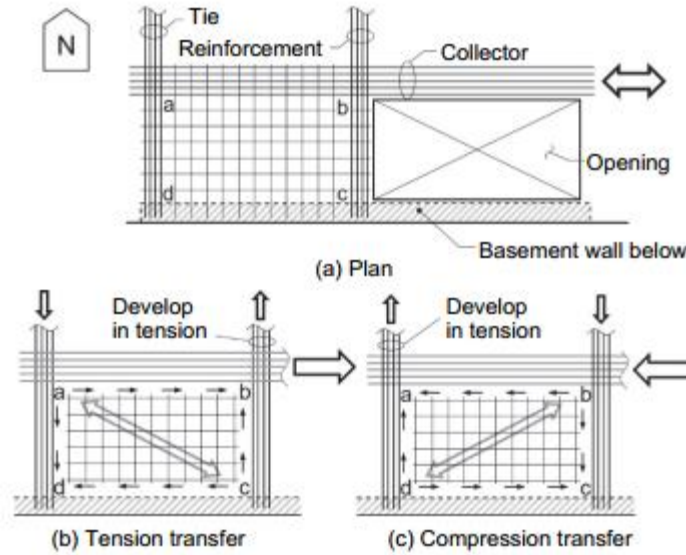

Figure 25. Reinforcement to transfer collector force around an opening.

7.5.2 Re-Entrant Corners

At re-entrant corners of diaphragms, such as shown in **Figure 26**, either tension chord from Point a to Point d can extend across the full width of the diaphragm, or the chord can be provided in segments that extend along the edge of the diaphragm as shown. A strut-and-tie model can be used to define design forces in the zone bounded by Point b, Point c, and Point e. As shown, the horizontal component of the chord force at Point c can be transferred through a diagonal compression strut to Point e. The chord bars at Point c need to be extended a development length beyond the node at Point c. Both North-South (NS) and East-West (EW) reinforcement are required to extend from the node at Point e, with overlapping hooks to provide development of the forces at the node. Finally, the design of tension chord between Point e and Point f can be based on the corresponding moment and effective depth.

The NS component of the diagonal compression strut at Point c can be resisted by compression in the adjacent diaphragm. Nonetheless, a NS steel ratio not less than 0.0025 should be provided in this region, as recommended by this Guide wherever strut-and-tie models are used.

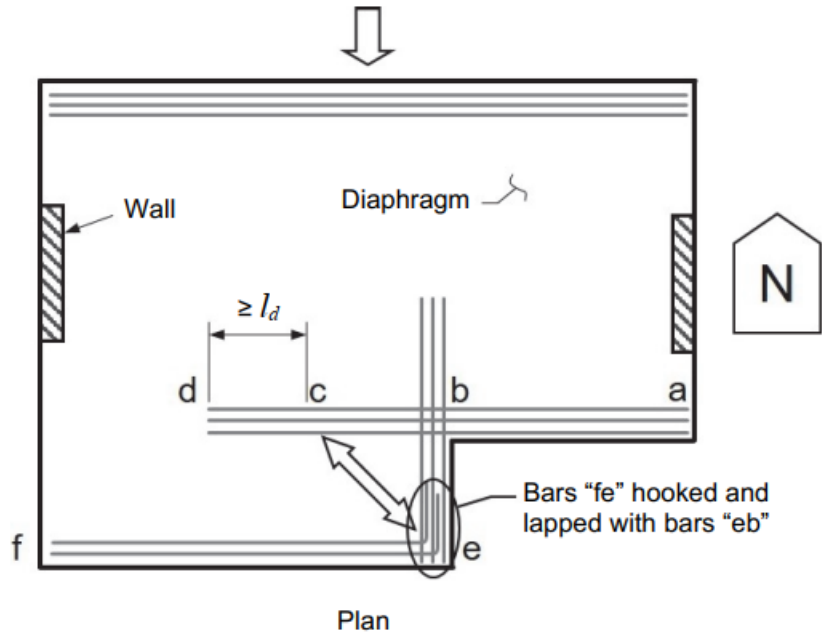

Figure 26. Reinforcement associated with re-entrant corners

7.5.3 Steps and Depressions

Where steps or depressions occur, reinforcement must be provided to transfer the design forces through the offset. **Figure 27** illustrates collector reinforcement passing through a step and depression. **Figure 27b** shows flexural cracking of the depression that could be induced by the eccentric loading.

To the extent practicable, collector reinforcement should be placed to minimize the eccentricity on opposite sides of the step when in tension. If the collector also transmits compression, the eccentricity is determined by the gross dimensions of the offset. If collector reinforcement cannot be placed straight, either it can be bent or bent bars can be spliced with the main bars. The vertical force created by offset bars should be resisted by hoop legs. See analogous provisions for offset column bars in ACI 318 §10.7.6.4. In addition, any eccentricity in the collector bars creates a moment Tue that must be resolved within the structure. If there is a wall at this location oriented perpendicular to the collector, the wall may be able to resist the moment by out-of-plane bending.

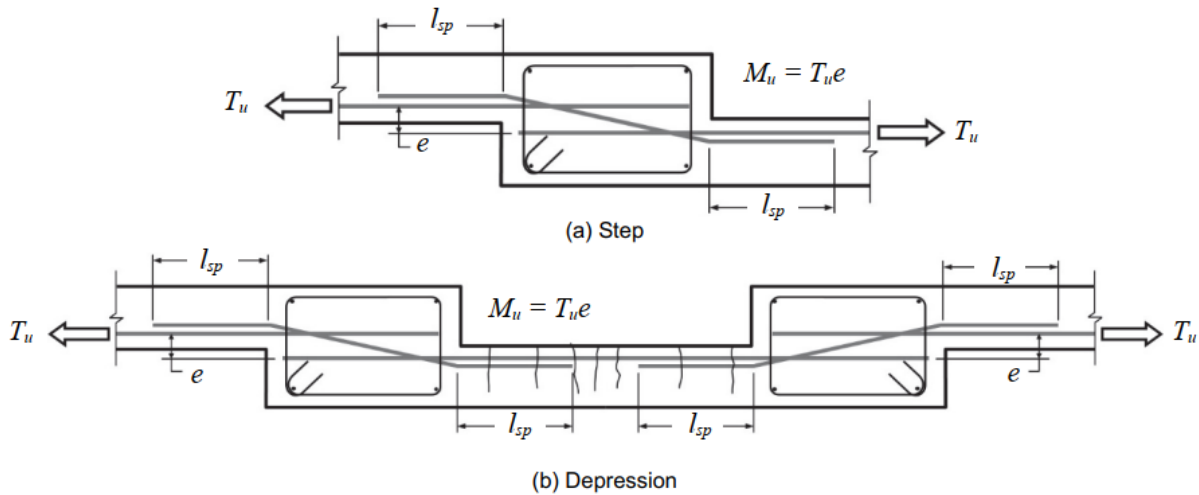

Figure 27. Collector reinforcement passing through a step and depression

Alternatively, the overlapped section of the step can be reinforced as a beam to transmit moment through torsion to adjacent columns, although this can be problematic because of challenging reinforcement details and because of large twist that may be associated with torsion. If the diaphragm is transmitting shear across the step, hoop reinforcement can resist the applied shear through shear friction at the interface. “Sawtooth” diaphragms, in which the entire diaphragm is stepped, create obvious problems if chords or collectors have to pass across the step.

7.5.4 Extension of Collectors into Diaphragms

Collectors can extend the full depth of a diaphragm or partial depth, depending on the assumed load path. See Section 6 for more information on diaphragm analysis. Where forces are transferred from a vertical element into a transfer level, the length of the collector is sometimes selected based on the length required to transfer its force into the diaphragm. In most cases, the required collector length is equal to the total transfer force divided by the shear strength per unit length of the diaphragm. By this approach, tension in a collector decreases linearly along its length. Common practice is to stagger bar cutoffs along the length, maintaining design strength not less than the tension force at any section. As discussed in Section 6.3, long collectors can be problematic.

7.5.5 Reinforcement Development

ACI 318 requires that all reinforcement used to resist collector forces, diaphragm shear, or flexural tension to be developed or spliced for f_y in tension. Reductions in development or splice length for calculated stresses less than f_y are not permitted. Mechanical splices, if used to transfer forces between the diaphragm and vertical elements of the seismic force-resisting system, must be Type 2 per ACI 318 §18.2.7.1.

8. Additional Requirements

8.1 Materials Properties

ACI 318 §19.2 requires minimum specified compressive strength f_c' , of 2,500 psi (17 MPa) for structural concrete including diaphragms, although f_c' at least 3,000 psi (21MPa) is recommended here. Where diaphragms are cast monolithically with portions of special moment frames or shear walls for a structure assigned to Seismic Design Category D, E, or F, the minimum f_c' is 3,000 psi (21 MPa) (ACI 318 §19.2) for that part of the diaphragm. This is typically not an issue because f_c' of 4,000 to 6,000 psi (28 to 41 MPa) is commonly specified for floor systems.

For some structures, specified concrete strength of moment frame columns or shear walls is higher than that of the diaphragm/floor system. ACI 318 §15.3, which allows column concrete compressive strength to be 1.4 times that of the floor system, is intended to apply only for axial load transmission and therefore should not be applied to walls or columns of the seismic force-resisting system. Many walls or moment frame columns are located along edges of the building slab or along openings, where the concrete is not confined by adjacent concrete on all sides. Additionally, these elements have high shear stress that must be transferred through the floor, requiring the higher strength.

For shear walls, the higher wall strength can be maintained using a jump core or flying form system for the wall construction to precede the floor construction. Where concrete for the portion of the wall or moment frame through the thickness of the floor system is placed with concrete for the floor system, the higher strength concrete should be puddled at these elements and extended 2 feet (0.6 m) into the slab as allowed for columns in ACI 318 §15.3.1 and also described in commentary section R15.3.

Where lightweight concrete is used, the provisions of ACI 318 §19.2 apply if the diaphragm concrete is also part of a special moment frame or special shear wall.

According to ACI 318 §20.2.2.4 the values of f_y and f_{yt} used in design of reinforcement resisting shear shall not exceed 60,000 psi (420 MPa), except the value shall not exceed 80,000 psi (550 MPa) for welded deformed wire reinforcement. The intent of the code requirement is to limit the width of shear cracks.

Reinforcement for chords and collectors is limited by the general requirements for bonded reinforcement of ACI 318 Chapter 20, with two exceptions.

(a) Where chord or collector reinforcement is placed within beams, including the effective flange of special moment frames, and therefore acts as the beam flexural reinforcement, the chord or collector reinforcement must comply with ASTM A706, *Standard Specification for Deformed and Plain Low-Alloy Steel Bars for Concrete Reinforcement* (ASTM 2016), or equivalent.

(b) ACI 318 §12.5.1.5 limits the stress from design earthquake forces to 60,000 psi (420 MPa) for bonded tendons. Although the stress in other collector and chord reinforcement is not limited, consideration should be given to deformation compatibility between tension chords, collectors, and the floor slab. High tensile stress and strains in collectors and chords can result in excessive cracking that will migrate into the slab. This, in turn, can negatively affect shear strength. Therefore, this Guide recommends limiting the usable design stress to 80,000 psi (550 MPa) for reinforcement.

8.2 Special Inspection

Reinforced concrete diaphragms and their chords and collectors are a part of the seismic force-resisting system. Proper construction of diaphragms and their elements is paramount to ensuring that the structure will perform as intended during a major earthquake. The IBC requires that the design professional for a building prepare a statement of special inspections identifying the required inspections for construction of the building. This Guide recommends that inspection of diaphragms include collector reinforcement placement and spacing, surface roughness at diaphragm-to-wall connections, reinforcement placement and spacing at diaphragm-to-wall connections, and splices.

The special inspector is required to inspect work for conformance to the approved design drawings and specifications. Per IBC §1704, the engineer of record should designate the specific inspections and tests to be performed in a Statement of Special Inspections, submitted as part of the permit application. Contract documents should specify that the special inspector will furnish inspection reports to the building official, the engineer of record, owner, and

contractor. Discrepancies should be brought to the immediate attention of the contractor for correction, then, if uncorrected, to the proper design authority and the building official. A final signed report is to be submitted stating whether the work requiring special inspection was, to the best of the inspector's knowledge, completed in conformance with the approved plans and specifications and the applicable workmanship provisions of the IBC and its referenced standards.

8.3 Bracing Columns to Diaphragms

Diaphragms brace columns where they connect. See fourth bullet of Section 2. The force required to brace a column is not defined in ACI 318, but a force of 2 percent to 4 percent of the column axial load is generally considered sufficient. For low and midrise cast-in-place concrete buildings, this check is rarely made as the inherent strength of diaphragm-to-column connections easily provides this strength. For tall buildings with large heavily loaded columns, this check should be made. For these columns, the diaphragm check should include bearing stresses at the face of the column, adequacy of diaphragm reinforcement anchored into the column at edge conditions, and adequate diaphragm buckling strength to resist the bracing force. These requirements and recommendations also apply to precast buildings with cast-in-place diaphragms.

Inclined columns require a more rigorous check of forces at the diaphragm-to-column interface. At the top and bottom of the inclined portion of a column, there is a horizontal component of force imparted on the diaphragm that the diaphragm must resist and deliver to vertical elements of the seismic force-resisting system (**Figure 2**). The magnitude of this horizontal component depends on the inclination of the column. Where architecturally feasible, the column inclination from vertical should not exceed about 15° (one to four, horizontal to vertical). Larger inclination angles are not generally prohibited by the building code, but large diaphragm thrusts and challenges in adequately reinforcing the column, diaphragm, and diaphragm column connection should be anticipated. Where the column axial loads are low and the inclination approaches vertical, the slab may be capable of resisting the horizontal component. The slab may also be adequate at intermediate levels where the inclined column passes without a change in direction. At these intermediate levels, only the incremental vertical force added to the column at that level creates a horizontal thrust for which the connection must be designed. For highly loaded inclined columns and columns with inclines from vertical greater than 15°, it may be necessary to thicken the slab or provide a beam to transfer the thrust from the inclined column.

8.4 Interaction of Diaphragm Reinforcement with Vertical Elements

Chord and collector reinforcement of diaphragms is often located in beams that are part of special moment frames or within slabs adjacent to those beams. This reinforcement will likely not be stressed to its yield strength from chord or collector forces during the earthquake at the same time the moment frame beam is fully yielding. However, deformation compatibility will typically dictate that chord or collector reinforcement will yield along with the beam (the reinforcement will strain as the beam flexes). Therefore, this chord or collector reinforcement will add flexural strength to the beam. This added flexural strength must be considered as part of the beam strength when proportioning the beam and column to meet the strong-column-weak beam requirements of ACI 318 §18.7.3. If the chord or collector reinforcement is within the beam, the added flexural strength must also be included when determining the probable flexural strength used to compute the design shear force for the beam as required by ACI 318 §18.6.4 and when determining requirements for beam-column joint strength. (A strict interpretation of the ACI 318 provisions is that this reinforcement need not be included in beam and beam-column joint shear calculations if it is located in the beam effective flange width rather than within the beam web; however, the preferred approach is to include it in all cases where it is located within the effective beam width.) Similar considerations should be made when designing coupling beams for shear walls in accordance with ACI 318 §18.10.7.1.

Collector or chord compressive forces can also increase the flexural strength of beams as the axial force is likely below the balance point. In determining the compressive force of a chord to add to a beam, only 30 percent of the chord force is likely required as the chord force is usually caused by earthquake forces orthogonal to forces loading the moment frame. Collector forces that act on beams are likely caused by the same earthquake force that loads the moment frame. Therefore, 100 percent of the collector force is likely required to be considered when designing the beam. Similar considerations apply to chord and collector tension forces. These axial forces should be considered when evaluating strong-column weak-beam requirements and when determining the beam design shear force and design shear strength. Similar considerations also apply to the design of intermediate moment frames.

Collectors and chords are designed to respond linearly under axial tension and compression, but where these elements enter the boundaries of shear walls, they may be subjected to significant flexure as the walls rock back and forth during an earthquake. Where possible, the reinforcement of these elements should be located to minimize flexural yielding. This may be achieved by using shallower members or by placing the main collector or chord reinforcing bars near the mid-depth. Transverse confining reinforcement is recommended for structures assigned to Seismic Design Category D, E, or F, at these locations in order to improve the compressive capacity of the concrete and buckling resistance of the reinforcement.

9. Detailing and Constructability Issues

9.1 Diaphragm Reinforcement

Many concrete slabs are designed to have a continuous bottom mat of uniformly distributed reinforcement. For this reason, transverse reinforcement provided for diaphragm shear resistance is commonly incorporated into the bottom mat. In heavily reinforced diaphragms that are thick slabs, a continuous top and bottom mat of reinforcement is often provided. Designers should specify the required lap splice and development length of the reinforcement in the construction documents, as diaphragm reinforcement splice and development requirements may exceed what is otherwise required for slabs supporting gravity loads only.

In post-tensioned slabs, the location of diaphragm reinforcement needs to be coordinated with the locations of post-tensioned strands and associated anchorages. Designating layers within the slab depth for the diaphragm reinforcement and the post-tensioned strands is an effective method of minimizing conflict. The design of the slab needs to take into account the actual location of the layers of reinforcement if this approach is used.

Welded wire fabric is not generally used for diaphragm reinforcement in cast-in-place slabs because the reinforcement provided for the gravity loading uses standard reinforcing bars. The use of welded wire fabric for diaphragm reinforcement is typically limited to topping slabs over precast concrete systems or over steel metal decks.

9.2 Collector and Chord Detailing

Collector and chord reinforcement is often located in the mid-depth of the slab. In structures assigned to Seismic Design Category D, E, or F, ACI 318 requires that center-to-center spacing at least $3d_b$, but not less than 1.5 inches (38 mm), and concrete clear cover at least $2.5d_b$, but not less than 2 inches (50 mm). Otherwise, transverse reinforcement is required. Connections of collector reinforcement to vertical elements of the seismic force-resisting system are often congested regions. In many cases, numerous large diameter bars are required to be developed into confined boundary zones of shear walls as shown in Figure 28a. Designers should study these connections in detail to ensure adequate space exists. In many cases, increased slab thickness or beams are required to accommodate reinforcement detailing at the connections. Figure 28b shows where a beam was created to accommodate the collector reinforcement, but congestion still may impede both placement of concrete and ultimate performance. Designers should also consider the slab depth provided where large collectors

intersect. Multiple layers of large diameter reinforcing bars can result in excessive congestion. Similarly, designers should be aware of locations where collectors intersect concrete beam longitudinal reinforcement.



(a) Collector connection to shear wall boundary zone



(b) Beam for large collector

Figure 28. Collector detailing.

Long collectors, such as the one shown in Figure 29, can accumulate strains over their length, resulting in displacements that may be incompatible with modeling assumptions or deformation capacities of adjacent components. Designers can consider additional collector

reinforcement to reduce the strain and the associated collector elongation. In addition, providing confinement reinforcement can also increase the ductility of the concrete locally, but will not address potential problems associated with any incompatible deformations. Redesigning the force transfer system should also be considered.

Where collector (or chord) reinforcement is required at a location coincident with a beam, the chord reinforcement can be placed within the beam. Beam transverse reinforcement, if properly detailed, can also serve as collector (or chord) confinement. If chord reinforcement does not fit entirely within the beam width, then the effective diaphragm depth should be based on the actual distribution and location of the chord reinforcement.



Figure 29. A long collector with confinement reinforcement

9.3 Confinement

Transverse (confinement) reinforcement may be required in collectors or other elements transferring axial forces around openings or other discontinuities. The required seismic hook dimensions can sometimes make reinforcement detailing difficult in typical slab depths. If there are concerns over congestion, designers can increase the width of the collector within the slab or the thickness of the slab until the compressive stresses are low enough that confinement is not required. Alternatively, beams with sufficient dimensions can be added to facilitate the required confinement detailing. Where confinement is not required by the code, the designer still may consider adding some transverse reinforcement to improve connection toughness at

critical locations. Figure 29 and Figure 30 show examples of added transverse reinforcement that is not in the form of closed hoops yet will result in improved collector behavior.



Figure 30. Confinement of a collector

9.4 Shear Transfer

Shear transfer between diaphragms and vertical elements of the seismic force-resisting system can be accomplished in a number of ways. Shear-friction reinforcement can be provided for transfer of forces along the length of the vertical element. For cases where the vertical elements of the seismic force-resisting system are cast in advance of the slabs, or vice versa, the use of shear keys should be considered to achieve a coefficient of friction, μ , of 1.0. There is no standard practice for shear keys. As an example, shear keys for an 8-inch (200-mm)-thick slab might be $\frac{3}{4}$ inches (20 mm) deep \times $3\frac{1}{2}$ inches (90 mm) tall \times 8 inches (200 mm) wide spaced 12 inches (300 mm) on center, centered within the slab thickness.

Shear-friction reinforcement must be developed at each critical failure plane, and the designer should consider the location of the construction joint when selecting μ during design.

Compressive collector forces can be transferred via direct bearing at wall ends. An appropriate effective slab bearing area should be considered, and compressive stresses in the slab should be evaluated to determine whether confinement is required.

Tensile forces can be transferred through collector reinforcement that is developed in both the diaphragm and the vertical element. The length of tension collectors within the diaphragm should consider the assumed shear stress distribution as well as the shear strength of the diaphragm. The length within the vertical element must be sufficient to fully transfer the force to the vertical element. See Section 6.8 for more information on diaphragm-to-vertical-element force transfer.

9.5 Mechanical Splices

Large diameter diaphragm and collector reinforcing bars are commonly spliced using mechanical couplers. Because lap splices of No. 14 bars or larger are prohibited by ACI 318, mechanical couplers are required. For smaller diameter bars, mechanical splices may be implemented as a means to reduce reinforcement congestion within a slab. Mechanical splices used to transfer forces between the diaphragm and the vertical elements of the seismic force-resisting system are required to be Type 2 per ACI 318 §18.2.7.1. Mechanical couplers considered for a project should have current ICC approval. Detailing and placement must provide the required cover over the coupler body, which has a diameter larger than the diameter of the bars being coupled.

Many contractors choose to cast vertical elements of the seismic force-resisting system in advance of the slabs. Mechanical splice and anchorage devices facilitate these construction methods. Approved form-face couplers are commonly used for anchorage of shear-friction and collector reinforcement. Designers should pay attention to the size of the couplers because they are typically large relative to the bar being anchored. Figure 31 shows shear-friction reinforcement connections to a shear wall with approved form-face couplers.



Figure 31. Form-face couplers for dowel anchorage.

9.6 Conduits and Embedded Services

The placement of electrical conduit, plumbing sleeves, and other services within a reinforced concrete slab is common practice. Figure 32 shows an example of embedded conduit within a reinforced cast-in-place concrete diaphragm. This example appears extreme, but similar conditions are often encountered.



Figure 32. Embedded conduit

Designers should consider these and similar items that can reduce the strength and stiffness of the diaphragm. Typical details showing restrictions on the placement of conduits and embedded services and associated supplemental reinforcement are helpful but often are insufficient to cover many of the conditions that occur in a project. The specifications or General Notes should identify specific mandatory restrictions; for example, for post-tensioned construction, it could be mandatory that conduit or other embedded items not displace the vertical profile of the tendons. Contract Documents should require the contractor to provide detailed layout drawings of the conduits and other embedded services well in advance of concrete placement. This allows the designer time to review the impact to the diaphragm and to provide supplemental instructions, including additional reinforcement, as required. Pre-construction meetings can provide an opportunity for the designer to review embedment placement and reinforcement requirements in detail prior to construction.

The location of nonstructural items embedded into the slab should also be considered with respect to collector layout. In many instances, conflicts between structural and nonstructural items can be problematic. Figure 33 shows a conflict in the location of a nonstructural component embedment with the alignment of the collector reinforcement.



Figure 33. Conflict between the location of collector reinforcing with a nonstructural component.

9.7 Location of Construction Joints

Construction joints create weakened planes within a diaphragm. They can also impact development and splices of reinforcement. Shear-friction reinforcement can be provided across construction joints, if necessary, to maintain continuity of the diaphragm in shear. The impacts to the continuity and development of chord and collector reinforcement at construction joints should also be understood. As with conduits, typical details, limitations, and instructions should be clearly detailed in the Contract Documents, which should also require that contractors provide detailed construction joint layout drawings well in advance of concrete placement.

References

- 1) ASCE, 2022, Minimum Design Loads for Buildings and Other Structures, ASCE/SEI 7-22, American Society of Civil Engineers, Structural Engineering Institute, Reston, Virginia.
- 2) ASCE, 2017, Seismic Evaluation and Retrofit of Existing Buildings, ASCE/SEI 41-17, American Society of Civil Engineers, Structural Engineering Institute, Reston, Virginia.
- 3) Building Code Requirements for Structural Concrete (ACI 318-19) and Commentary, ACI , Farmington Hills, Michigan, USA
- 4) Chopra, A.K. (2005). *Earthquake dynamics of structures: A primer*, Second Edition, Earthquake Engineering Research Institute, Oakland, CA
- 5) Deierlein, G., Reinhorn, A.M., and Willford, M. (2010). Nonlinear structural analysis for seismic design, NIST GCR 10-917-5, *NEHRP Seismic Design Technical Brief No. 4*, National Institute of Standards and Technology, Gaithersburg, MD
- 6) Fleischman, R.B., Farrow, K.T., and Eastman, K. (2002). Seismic performance of perimeter lateral system structures with highly flexible diaphragms, *Earthquake Spectra*, Vol. 18, No. 2, pp. 251-286.
- 7) LATBSDC (2014). An alternative procedure for seismic analysis and design of tall buildings located in the Los Angeles region, Los Angeles Tall Buildings Structural Design Council.
- 8) Nakaki, S.D. (2000). Design guidelines for precast and cast-in-place concrete diaphragms, *EERI professional fellowship report*, Earthquake Engineering Research Institute, Oakland, CA
- 9) PEER (2010). Guidelines for performance-based seismic design of tall buildings, PEER Report 2010/05, prepared by the TBI guidelines working group, Pacific Earthquake Engineering Research Center, University of California, Berkeley, Berkeley, CA.
- 10) Rodriguez, M.E., Restrepo, J.I., and Blandón, J.J. (2007). Seismic design forces for rigid floor diaphragms in precast concrete building structures, *Journal of Structural Engineering*, Vol. 133, No. 11, pp. 1604-1615.

- 11) Sabelli, R., Pottebaum, W., and Dean, B. (2009a). Diaphragms for seismic loading, Part 1, *Structural Engineer*, January, pp. 24-29.
- 12) Sabelli, R., Pottebaum, W., and Dean, B. (2009b). Diaphragms for seismic loading, Part 2, *Structural Engineer*, February, pp. 22-23
- 13) SEAOC (2005). Using a concrete slab as a seismic collector, Seismology and Structural Standards Committee, Structural Engineers Association of California, April, Sacramento, CA.
- 14) Shakal, A.F., Huang, M.J., Darragh, R.B., Brady, A.G., Trifunac, M.D., Lindvall, C.E., Wald, D.J., Heaton, T.H., and Mori, J.J. (1995). Recorded ground and structure motions, *Earthquake Spectra*, Vol. 11, No. S2, pp. 13-96.