



*An Online PDH Course
brought to you by
CEDengineering.com*

**Seismic Design of Coupled Composite Plate Shear
Walls (C-PSWCFs) per ANSI/AISC 341-22 &
ASCE/SEI 7-22**

Course No: S04-026
Credit: 4 PDH

Ibrahim M. Metwally, Ph.D., P.E.



Continuing Education and Development, Inc.

P: (877) 322-5800
info@cedengineering.com

This course was adapted from the Federal Emergency Management Agency, Publication No. FEMA P-2192-V1, “2020 NEHRP Recommended Seismic Provisions: Design Examples, Training Materials, and Design Flow Charts”, which is in the public domain.

COURSE CONTENT

Composite Plate Shear Wall / Concrete Filled (C-PSW/CF), also known as the SpeedCore system, is an efficient seismic force-resisting system for buildings, which was already addressed in ASCE/SEI 7-16. Coupled C-PSW/CF are more ductile and have more redundancy than uncoupled composite plate shear walls, but ASCE/SEI 7-16 did not assign them seismic design coefficients in Table 12.2-1. A FEMA P695 study was conducted to substantiate the design coefficients that should be used for such coupled C-PSW/CF structures. Adding this as a separate category in Table 12.2-1 was important because modern high-rise buildings often have elevator core wall systems; many of these core walls could utilize the coupled C-PSW/CF systems. Two-line items featuring this system are now added to ASCE/SEI 7-22 Table 12.2-1 under Building Frame Systems and Dual Systems with Special Moment Frames. $R = 8$, $C_d = 5.5$, and $\Omega_0 = 2.5$ are the design coefficients in both line items. The height limits are the same as for corresponding uncoupled isolated wall systems.

A definition for the coupled C-PSW/SF system and design and detailing requirements for it are so far not given in ANSI/AISC 341-16 (AISC, 2016a) or ANSI/AISC 360-16 (AISC, 2016b). A new Section 14.3.5 in ASCE/SEI 7-22 (ASCE, 2021) includes specific provisions for the definition and application of this coupled C-PSW/CF system, including details on the design philosophy and limits on applicability. It is anticipated that the provisions in Section 14.3.5 will ultimately end up distributed in ANSI/AISC 341-22 (AISC, 2022a) and AISC 360-22 (AISC, 2022b). Rather than construct the requirements in Section 14.3.5 to modify the applicable sections of ANSI/AISC 360-22 and ANSI/AISC 341-22, it is presented as a completely new comprehensive section in ASCE/SEI 7-22 for clarity.

This course outlines the above developments and presents a *detailed design example* illustrating the coupled C-PSW/CF seismic force-resisting system.

1. Introduction

Functional and often structural requirements make the use of shear walls desirable in many buildings. Functionally, shear walls are useful in buildings because they serve as partitions between spaces. Structurally, they make buildings laterally stiff, thereby helping to keep lateral deflections within acceptable limits. Often, such walls are pierced by numerous openings for windows, doors, and other purposes. Two or more walls separated by vertical rows of openings, with beams at every floor level between the vertically arranged openings, are referred to as coupled shear walls. When a coupled shear wall system is subject to lateral loads due to wind or earthquake forces, shear forces generated at the ends of the coupling beams accumulate into a tensile force in one of the coupled wall piers and into a compression force in the other wall pier. The couple, due to these tension and compression forces, resists a part of the overturning moment at the base of the wall system, with the remainder of the overturning moment being resisted by the wall piers themselves (Figure 1). The ratio of the overturning moment resisted by the tension-compression couple to the total overturning moment at the base of the coupled wall system is often referred to as the degree of coupling. The shorter and deeper the coupling beams, the higher the degree of coupling. When the degree of coupling is very low, the two wall piers tend to behave like isolated walls, and when the degree of coupling is very high, the entire coupled wall system tends to behave like a shear wall with openings. It should be noted, however, that as and when inelastic displacements develop in the coupling beams, the degree of coupling tends to lose its significance.

A coupled shear wall system can be designed such that a considerable amount of earthquake energy is dissipated by flexural yielding in coupling beams before flexural hinge formations (typically) at the bases of the wall piers. Coupling beams are required to have length-to-depth ratios between three and five. Wall piers are required to have height-to-length ratios larger than or equal to four. Although such coupled wall systems are highly suitable as the seismic force-resisting systems of multistory buildings, they are not recognized as distinct entities in Table 12.2-1 of ASCE/SEI 7-16. Therefore, such systems need to be designed using R -values that essentially ignore the considerable benefits of having the coupling beams, which can dissipate much of the energy generated by earthquake excitation. This course reports on a successful effort to remedy this situation.

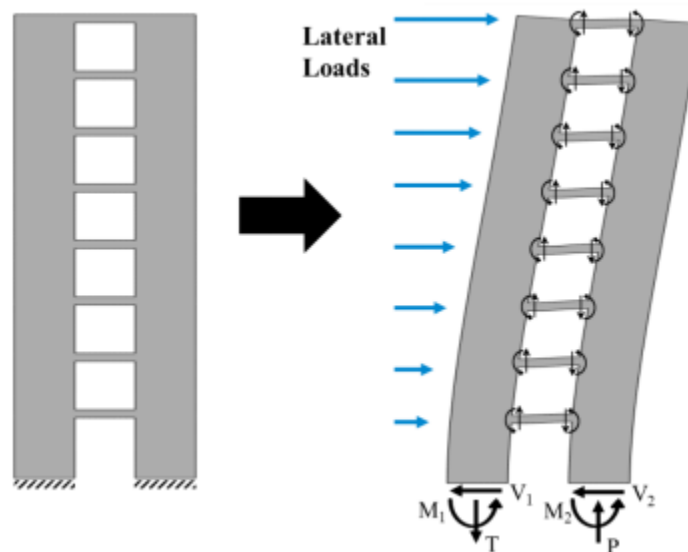

Figure 1- A Coupled C-PSW/CF Subjected to Lateral Loads

2. Coupled Composite Plate Shear Wall / Concrete Filled (C-PSW/CF) Systems

C-PSW/CFs are an alternative to conventional reinforced concrete (RC) shear walls and core wall structures in building structures. Similar to RC walls, composite walls provide the stiffness, strength, and deformation capacity needed to serve as the primary lateral force-resisting system. C-PSW/CFs may be used as the elevator core structure or as individual shear walls in building structures. Two versions are possible: uncoupled and coupled. In a given building structure, it is possible to have coupled system in one direction and uncoupled system in the orthogonal direction.

The coupled C-PSW/CF system consists of: (i) composite C-PSW/CFs and (ii) composite coupling beams. Both the composite walls and composite coupling beams consist of a concrete core sandwiched between two steel plates that serve as the primary reinforcement, completely replacing conventional rebars. Figure 2(a) shows a typical C-PSW/CF with its components. Tie bars connect the two steel plates together and provide stability during transportation and construction activities. After concrete casting, the tie bars become embedded in the concrete infill and provide composite action between the steel and concrete. The coupling beams are built-up steel box sections with concrete infill. Figure 2(b) shows a composite coupling beam. Similar to the composite walls, the

built-up steel section provides primary reinforcement to the coupling beam. The empty steel modules, including both the walls and the coupling beam components, are typically fabricated in the shop, transported to the site, erected, and filled with concrete. The composite walls can be planar, C-shaped, or I-shaped, following the typical geometric configurations of conventional concrete core walls.

It is important to note that there are no additional reinforcing bars needed in either the C-PSW/CFs or the composite coupling beams. The empty steel modules are filled with plain concrete, which is usually self-compacting concrete (SCC). There are no temperature and shrinkage concerns related to strength. The effects of concrete cracking due to locked-in shrinkage strain are included in the stiffness equations. The steel plates provide all the reinforcement needed to resist forces. The steel modules, including the plates, tie bars, and shear studs (if used), are pre-fabricated in the shop and shipped to the field for assembly and erection. The modular steelwork serves as formwork for the concrete infill and falsework for construction activities. Generally, the steel parts come without painting, but after assembly, they might be painted or fireproofed, if needed (Anvari et al. 2020). Commercial interest in the coupled C-PSW/CF system is motivated by these potential advantages of modularity, construction schedule, and overall project economy. In addition, another benefit of using C-PSW/CFs is that they are thinner than corresponding reinforced concrete shear walls, providing more available floor area.

The composite walls are required to have height-to-length (h_w/L_w) ratio greater than or equal to 4.0. This requirement is specified to ensure that the walls are flexure critical, i.e., flexural yielding and failure governs behavior rather than shear failure. Calculations can also be performed to show that the wall is flexure critical, i.e., plastic hinges (with expected flexural capacity) form at the base of the walls before shear failure occurs. The shortest archetype structure that was evaluated using the FEMA P695 approach for this system was three stories with two 45 feet tall composite walls with 10-foot length (Bruneau et al. 2019), corresponding to a height-to-length ratio equal to 4.5 for each wall.

The composite coupling beams are also required to be flexure critical, i.e., flexural yielding and failure governs behavior rather than shear failure. Calculations can be performed to show that the composite beam is flexure critical, i.e., plastic hinges (with expected flexural capacity) form at the ends of the beams before shear failure occurs. For at least 90% of the stories of the building, composite coupling beams are also required to have clear length-to-section depth ratios greater than or equal to 3.0 and less than or equal to 5.0, i.e., $3.0 \leq L/d \leq 5.0$. This requirement is specified based on the range of parameters included in the FEMA P695 studies conducted to establish the seismic factor (R etc.) for the system.

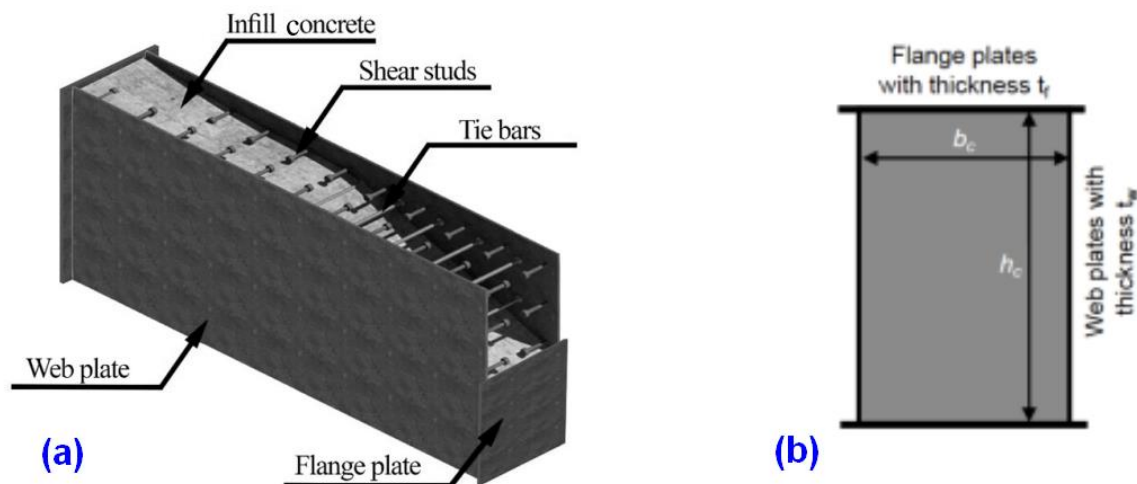

Figure 2. Components of: (a) C-PSW/CF (Shafaei et al. 2021b), and (b) Composite Coupling Beam

3. Coupled C-PSW/CF System in ASCE/SEI 7-22

Issue Team (IT) 4 of the Provisions Update Committee (PUC) of the Building Seismic Safety Council (BSSC) developed a proposal that led to the addition of two line items to ASCE/SEI 7-22 Table 12.2-1, Design Coefficients and Factors for Seismic Force-Resisting Systems, featuring the steel and concrete coupled composite plate shear walls (Table 1). The line items will be under: B. Building Frame Systems, and D. Dual Systems with Special Moment Frames.

Note: The coupled C-PSW/CF system is called "Steel and concrete coupled composite plate shear walls" in ASCE/SEI 7-22; however, "Coupled Composite plate shear walls / concrete filled" (coupled C-PSW/CF) name is used for this coupled system in ANSI/AISC 341-22 and AISC Design Guide 37.

Table 1. Addition of Coupled C-PSW/CF to ASCE/SEI 7-22 Table 12.2-1

Seismic Force-Resisting System	ASCE/SEI 7-22 Section Where Detailing Requirements Are Specified				Structural System Limitations Including Structural Height, (ft) Limits ^d				
					Seismic Design Category				
					B	C	D ^e	E ^e	F ^f
...									
B. BUILDING FRAME SYSTEMS									
...									
26. Steel special plate shear walls	14.1	7	2	6	NL	NL	160	160	100
<u>27. Steel and concrete coupled composite plate shear walls</u>	<u>14.3</u>	<u>8</u>	<u>2½</u>	<u>5½</u>	<u>NL</u>	<u>NL</u>	<u>160</u>	<u>160</u>	<u>100</u>
...									
D. DUAL SYSTEMS WITH SPECIAL MOMENT FRAMES CAPABLE OF RESISTING AT LEAST 25% OF PRESCRIBED SEISMIC FORCES									
...									
13. Steel special plate shear walls	14.1	8			NL	NL	NL	NL	NL
<u>14. Steel and concrete coupled composite plate shear walls</u>	<u>14.3</u>	<u>8</u>	<u>2½</u>	<u>5½</u>	<u>NL</u>	<u>NL</u>	<u>NL</u>	<u>NL</u>	<u>NL</u>

Based on a FEMA P695 study, $R = 8$, $C_d = 8$, and $\Omega_o = 2.5$ have been adapted in all the line items. The height limits are the same as for corresponding uncoupled isolated wall systems, eccentrically braced frames, steel special concentrically braced frames, steel buckling-restrained braced frames, and steel special plate shear walls. It will be possible to increase the 160-ft height limit to 240 ft for buildings without significant torsion because ASCE/SEI 7-22 Section 12.2.5.4 has been made applicable to these systems.

ASCE/SEI 7-22 Section 14.3.5 includes detailed requirements for the coupled C-PSW/CF system and its components, including the composite walls, composite coupling beams, and various connections, splices etc. These include:

1. A detailed discussion of the scope of the coupled C-PSW/CF system along with dimensional constraints and geometric requirements.

(a) For example, the wall height-to-length (h_w/L_w) ratio is required to be greater than 4 to achieve flexure critical behavior.

(b) The composite coupling beam clear length-to-section depth ratios are limited to values between 3.0 and 5.0 for at least 90% of the stories along the structure height to achieve flexure critical behavior.

2. The basis of design is that the coupled C-PSW/CF system, designed in accordance with the requirements of ASCE/SEI 7-22, provides significant inelastic deformation capacity through flexural plastic hinging in the composite coupling beams and through flexural yielding at the bases of the composite walls, as shown in Figure 3. Figure 3(b) shows typical milestones of the pushover behavior of a coupled C-PSW/CF including (a) flexural yielding of coupling beams (Point A), (b) formation of plastic hinges in coupling beams and flexural yielding of C-PSW/CF (Point B), (c) formation of plastic hinges in C-PSW/CFs at the base and fracture initiation in coupling beams (Point C), and (d) fracture initiation in C-PSW/CFs (Point D).

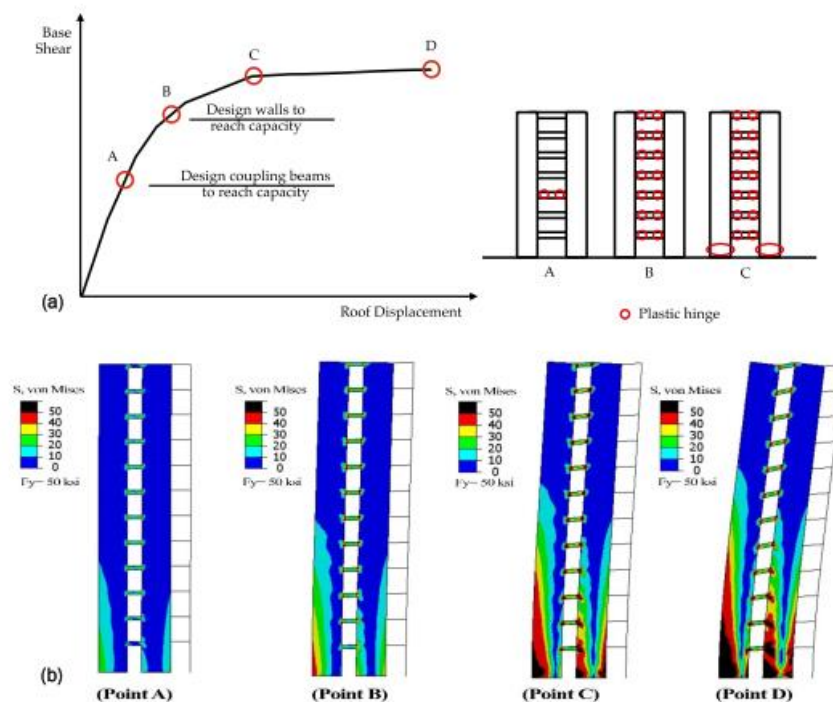

Figure 3. (a) Desired Pushover Response of Designed Coupled C-PSW/CFs (AISC Design Guide 37) (b) A Typical Pushover Response of Coupled C-PSW/CF using 2D Finite Element Modeling (Shafaei et al. 2022)

3. For conducting elastic analysis, the stiffnesses of composite walls and coupling beams can be estimated by section analysis accounting for the effects of concrete cracking or be based on recommendations provided in the ASCE/SEI 7-22 commentary or AISC 360-22.
4. The coupling beams are sized for code-level seismic forces and intended to yield before flexural yielding of C-PSW/CFs at the base, as shown in Figure 3 (Point A). The required strengths for the CPSW/CFs are determined using the capacity-limited seismic load effect, which is marked as “Point B” in Figure 3. In other words, the C-PSW/CFs are designed for amplified seismic forces corresponding to the formation of the plastic hinges in all coupling beams along the height of wall, as shown in Figure 3 (Point B).
5. The required shear strengths for the composite walls are amplified by a factor of 4 to account for higher mode effects, overstrength in the walls resulting from expected material properties and strain hardening. For reinforced concrete walls, this amplification factor is about 2-3 (ACI 318-19 Section 18.10), but a conservative value of 4 was used for composite walls in the absence of better information and in recognition of their inherent (significant) composite shear strength.
6. Design and detailing requirements for composite walls are specified, including minimum and maximum area of steel, plate slenderness requirement resulting in maximum spacing of ties and/or shear studs, and tie spacing requirements based on considerations of empty module behavior during construction and concrete casting.
7. Design and detailing requirements for composite coupling beams are specified, including the minimum and maximum area of steel, flange and web slenderness requirements, and flexure critical requirements.
8. Equations for calculating the design strength of composite walls in tension, compression, shear, and flexure are specified in ANSI/AISC 341-22. The design strength of composite walls subjected to combined axial force and flexure can be calculated using methods specified in ANSI/AISC 341-22 Chapter H8, Section 6d.
9. Equations for calculating the shear strength of composite coupling beams are specified, and the flexural strength is calculated using methods in ANSI/AISC 341-22 Chapter H8, Section 7.
10. Requirements for the coupling beam-to-wall connections are specified. These include requirements for developing the expected flexural and shear strength at the coupling beam ends and provide a rotation capacity of 0.030 rad. before flexural strength decreases to 80% of the flexural plastic strength of the coupling beam.
11. Requirements for composite wall-to-foundation connections are specified. These include the required strengths for the composite wall-to-foundation connections based on the capacity-limited seismic load effect.
12. Requirements for protected zones in the composite walls and coupling beam are specified, and requirements for demand critical welds in various splices and connections are specified.

4. FEMA P695 Studies Involving Coupled C-PSW/CFs

The FEMA P695 studies conducted on coupled C-PSW/CFs are summarized in Kizilarslan et al. (2021a). Since the coupled C-PSW/CF system is relatively new, this FEMA P695 study was performed using two different sets of nonlinear hysteretic models (Kizilarslan et al. 2021b) using OpenSees software: (i) distributed plasticity fiber models (Model 1) for both the composite walls and coupling beams, and (ii) distributed plasticity fiber models (Model 2) for the composite walls but concentrated plasticity models for the coupling beams. Both sets of models were calibrated extensively against experimental results, as detailed in Bruneau et al. (2019). Distributed plasticity fiber models were developed using effective stress-strain curves proposed by Shafaei et al. 2021a, which were developed based on detailed 3D finite element models of tested C-PSW/CF specimens. Both sets of models implicitly account for various limit states and failure modes, including steel yielding, local buckling, cyclic hysteresis, low-cycle fatigue and fracture, and concrete tension cracking, compression inelasticity and crushing, effects of confinement, and cyclic hysteretic crack opening-closing behavior with damage (Shafaei et al. 2021a).

The archetype structures focused on low-rise to mid-rise buildings (8-22 stories). The design space is divided into performance groups for the FEMA P695 study. The performance groups are differentiated based on basic configuration, design load level, and structure period. Two structural configurations under two seismic load levels were evaluated. These correspond to four performance groups (PG) with 16 archetypes designed and analyzed. The structure height governed the wall configuration of the archetypes as shown in Table 2. Three different coupling beam clear length-to section depth ratios ($L/d = 3, 4, \text{ and } 5$) were considered. The resulting details of the archetype structures are provided in Kizilarslan et al. (2021a) and not repeated here.

Table 2. Archetype Performance Group Summary Table

Case	Basic Configuration	Seismic Design Category (SDC)	No. Stories	L/d	Performance Group
PG-1A	Type I (Planar)	D_{max} ($S_{D08}=1.0g$ and $S_{D1}=0.6g$)	8	3	1
PG-1B				4	1
PG-1C				5	1
PG-2B	Type I (Planar)	D_{min} ($S_{D08}=0.5g$ and $S_{D1}=0.2g$)	8	4	2
PG-1D	Type I (Planar)	D_{max} ($S_{D08}=1.0g$ and $S_{D1}=0.6g$)	12	3	1
PG-1E				4	1
PG-1F				5	1
PG-2E	Type I (Planar)	D_{min} ($S_{D08}=0.5g$ and $S_{D1}=0.2g$)	12	4	2
PG-3A	Type II (C-shaped)	D_{max} ($S_{D08}=1.0g$ and $S_{D1}=0.6g$)	18	3	3
PG-3B				4	3
PG-3C				5	3
PG-4B	Type II (C-shaped)	D_{min} ($S_{D08}=0.5g$ and $S_{D1}=0.2g$)	18	4	4
PG-3D	Type II (C-shaped)	D_{max} ($S_{D08}=1.0g$ and $S_{D1}=0.6g$)	22	3	3
PG-3E				4	3
PG-3F				5	3
PG-4E	Type II (C-shaped)	D_{min} ($S_{D08}=0.5g$ and $S_{D1}=0.2g$)	22	4	4

Both the nonlinear hysteretic modeling approaches were used independently to conduct a detailed evaluation of the archetype structures in accordance with the FEMA P695 methodology.

1. Nonlinear pushover analyses were conducted to estimate the overstrength and period-based ductility for all archetypes.

2. Incremental dynamic analyses (IDA) were conducted by gradually scaling up ground motions from low to high magnitude until collapse. The default 44 far-field ground motions specified by FEMA P695 were considered and scaled appropriately for the archetype structures such that the median spectral acceleration of the 44 ground motions matched that at the design basis earthquake and maximum considered earthquake spectral acceleration levels.

3. For the coupled C-PSW/CF system, collapse was defined conservatively at 5% drift ratio. The archetype structure had much more reserve capacity, but at the recommendation of the provisions update committee and the recognition that extensive nonstructural damage could occur, 5% drift ratio was used conservatively to define collapse of the coupled C-PSW/CF system.
4. The results from the IDA were used to estimate the collapse margin ratio (CMR) values as the ratio of the median collapse spectral acceleration \hat{S}_{CT} to the median spectral acceleration S_{MT} for all the archetypes. The CMR values were adjusted to consider the frequency content of the selected ground motions records and calculate the adjusted collapse margin ratios (ACMR).
5. FEMA P695 specifies $ACMR_{20\%}$ and $ACMR_{10\%}$ (acceptable adjusted collapse margin ratio for 20% and 10% collapse probability under MCE ground motions) as the acceptable threshold values to evaluate the performance of individual archetypes and average performance of several archetypes in a performance group. These threshold values depend on the total system collapse uncertainty, which is a composite of uncertainty factors associated with ground motions, design requirements, test data, and nonlinear modeling. Using the values for “good” rating given in FEMA P695, the $ACMR_{20\%}$ and $ACMR_{10\%}$ are 1.96 and 1.56, respectively.
6. Results from the two independent FEMA P695 investigations are reported in Table 5-3. All the individual 8-, 12-, 18- and 22-story archetypes passed the $ACMR_{20\%}$ threshold (1.96) with a significant margin. Additionally, the average of the ACMR values in a performance group also passed the $ACMR_{10\%}$ threshold (1.56) with a significant margin. Even if values given for “poor” rating given in FEMA P695 were used, the ACMR values for the individual archetypes and the performance groups would still exceed the recalculated $ACMR_{20\%}$ and $ACMR_{10\%}$ thresholds.
7. Nonlinear Model 2 has a lower rotation capacity in the coupling beam-to-wall connections than Nonlinear Model 1. The coupling beam ends in Nonlinear Model 2 were modeled using concentrated plastic hinges that used envelopes of cyclic moment-rotation behavior that were marginally passing the connection rotation requirements (Kizilarslan et al. 2021).

Table 3. Summary of FEMA P695 Results for Archetypes by Performance Group

Perf. Group	Case	No. Stories	Nonlinear Model 1					Nonlinear Model 2				
			Pushover		IDA			Pushover		IDA		
			Ω_o	μ_T	CMR	ACMR	ACMR Avg.	Ω_o	μ_T	CMR	ACMR	ACMR Avg.
1	PG-1A	8	2.22	7.03	3.70	4.63	4.27	2.1	10.0	2.57	3.24	3.87
	PG-1B		2.14	7.84	3.03	3.82		2.0	12.0	2.44	3.10	
	PG-1C		1.96	8.50	2.77	3.55		2.1	12.7	2.61	3.35	
	PG-1D	12	2.33	5.89	3.10	4.05		2.3	7.5	3.57	4.68	
	PG-1E		2.33	6.54	3.78	4.95		2.3	10.3	3.44	4.51	
	PG-1F		2.15	6.88	3.50	4.62		2.1	11.3	3.31	4.37	
2	PG-2B	8	2.05	10.68	3.91	4.73	5.22	1.7	10.8	5.11	6.18	6.70
	PG-2E	12	2.13	7.86	4.72	5.71		2.3	7.7	5.48	7.21	
3	PG-3A	18	2.19	6.92	4.13	5.45	6.58	2.0	4.1	2.21	2.95	2.60
	PG-3B		2.38	8.14	3.84	5.07		2.1	4.9	1.85	2.45	
	PG-3C		2.23	9.85	3.60	4.75		2.0	5.6	1.79	2.14	
	PG-3D	22	2.55	5.29	4.94	6.52		2.1	3.5	2.11	2.78	
	PG-3E		2.31	5.94	6.65	8.78		2.0	4.6	1.98	2.64	
	PG-3F		2.38	7.90	6.74	8.90		2.2	4.9	2.01	2.64	
4	PG-4B	18	2.22	10.21	7.43	8.99	8.49	2.3	4.8	3.55	4.24	4.24
	PG-4E	22	1.89	6.47	6.60	7.99		2.6	3.4	3.73	4.24	

Results from the FEMA P695 evaluations of the 3-22 story archetypes indicate that the initial R factor of 8 used to design is adequate. The system overstrength factor is quite close to 2.5. Additionally, the C_d factor was assessed using the ratio of a median value of nonlinear inelastic drift ratios at design-basis shaking (δ_{in}) to the design level drifts (δ_e) from equivalent lateral force analysis. The stiffness values for estimating δ_e were based on the recommendations included in ASCE/SEI 7-22 Section 14.3.5 and in AISC 360-22. The C_d factor of 5.5 was deemed to be adequate for design.

5. Design of Coupled C-PSW/CF System

5.1 Overview

This example illustrates a seismic design of an 18-story office building using a coupled C-PSW/CF system according to ASCE/SEI 7-22. The steps followed in this design are in accordance with the design procedure presented in the 2020 *Provisions* (2020) and AISC Design Guide 37 (AISC, 2021). The 18-story office building is designed for typical design loads, floor geometry, and high seismic design loads.

In addition to the 2020 *Provisions* and ASCE/SEI 7-22, the following documents are either referred to directly or may serve as useful design aids.

Useful Design Aid Resources

AISC (2016a). *Seismic Provisions for Structural Steel Buildings*, ANSI/AISC 341-16, American Institute of Steel Construction.

AISC (2016b). *Prequalified Connections for Special and Intermediate Steel Moment Frames for Seismic Applications*, ANSI/AISC 358-16, American Institute of Steel Construction.

AISC (2016c). *Specification for Structural Steel Buildings*, ANSI/AISC 360-16, American Institute of Steel Construction.

AISC (2017). *Steel Construction Manual, 15th Edition*, American Institute of Steel Construction.

AISC (2021). *Design of Composite Plate Shear Walls / Concrete Filled (C-PSW/CF)*, AISC Design Guide 37, American Institute of Steel Construction.

AISC (2022a). *Seismic Provisions for Structural Steel Buildings*, ANSI/AISC 341-22, Committee on Specifications, American Institute of Steel Construction, Chicago, Illinois [under development].

AISC (2022b). *Specification for Structural Steel Buildings*, ANSI/AISC 360-22, Committee on Specifications, American Institute of Steel Construction, Chicago, Illinois, [under development].

Broberg, M., Shafaei, S., Kizilarslan, E., Seo, J., Varma, A. H., Bruneau, M. and Klemencic, R. (2022). "Capacity Design of Coupled Composite Plate Shear Walls - Concrete Filled (CC-CPSW/CF)," *Journal of Structural Engineering*, ASCE, Accepted.

Bruneau, M., Varma, A.H., Kizilarslan, E., Broberg, M., Shafaei, S., Seo, J. (2019). "R-Factors for Coupled Composite Plate Shear Walls—Concrete Filled (Coupled-C-PSW/CF)," *Final Project Report, Charles Pankow Foundation, CPF #06-16*, McLean, Virginia, 419 p.

Kizilarslan, E., Broberg, M., Shafaei, S., Varma, A.H., Bruneau, M., (2021a). "Seismic Design Coefficients and Factors for Coupled Composite Plate Shear Walls, Concrete Filled (Coupled-C-PSW/CF)," *Engineering Structures*, 244, 112766. <https://doi.org/10.1016/j.engstruct.2021.112766>

Kizilarslan, E., Broberg, M., Shafaei, S., Varma, A. H., & Bruneau, M. (2021b). "Non-linear analysis models for Composite Plate Shear Walls-Concrete Filled (C-PSW/CF)," *Journal of Constructional Steel Research*, 184, 106803. <https://doi.org/10.1016/j.jcsr.2021.106803>

Shafaei, S., Varma, A. H., Broberg, M., and Klemencic, R. (2021a). "Modeling the Cyclic Behavior of Composite Plate Shear Walls/Concrete Filled (C-PSW/CF)," *Journal of Constructional Steel Research*, 184, 106810. <https://doi.org/10.1016/j.jcsr.2021.106810>

Shafaei, S., Varma, A.H., M., Seo, J., and Klemencic, R. (2021b). "Cyclic Lateral Loading Behavior of Composite Plate Shear Walls / Concrete Filled (C-PSW/CF)," *Journal of Structural Engineering*, 147(10), 04021145. [https://doi.org/10.1061/\(ASCE\)ST.1943-541X.0003091](https://doi.org/10.1061/(ASCE)ST.1943-541X.0003091).

5.2 Building Description

Figure 4 shows the floor plan of the office building with 120 ft length and 100 ft width (a total of 12,000 square feet of area per floor). Coupled L-shaped Composite Plate Shear Walls / Concrete Filled (C-PSW/CFs) are used to resist seismic loads in north-south and east-west directions. Steel gravity frames are placed around the coupled C-PSW/CFs, and elevators and stairs are located inside the core walls, as shown in Figure 4. The composite metal deck floor is also used for the floor system design of the gravity frames, which is a typical gravity system associated with a CPSW/CF. This example presents the seismic design of coupled C-PSW/CF in an east-west direction.

Building Description

- Coupled L-shaped Composite Plate Shear Walls / Concrete Filled (C-PSW/CFs) are used to resist seismic loads.
- Steel gravity frames are placed around the coupled C-PSW/CFs, and elevators and stairs are located inside the core walls

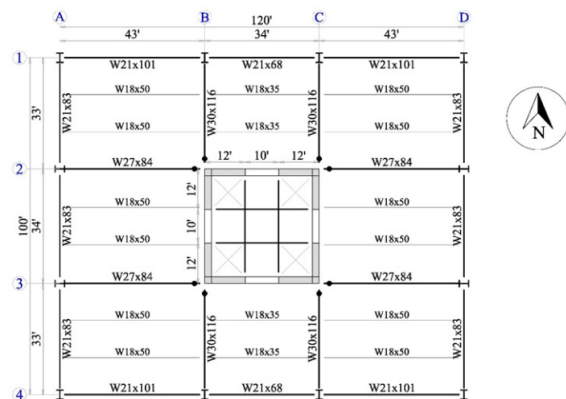

Figure 4. Typical Plan of 18-story Building Using a Coupled C-PSW/CF System

Figure 5 shows the section view of the coupled C-PSW/CF with perimeter steel gravity frames (Grid 3). The first story height is 17 feet, and the typical story height is 13 feet. Lengths of each L-shaped wall and coupling beam are 12 and 10 feet, respectively, which result in a total length of 34 feet for core system.

Building Description

- 18-story office building
- First story height = 17 ft
- Typical story height = 13 ft
- Total height = 238 ft.

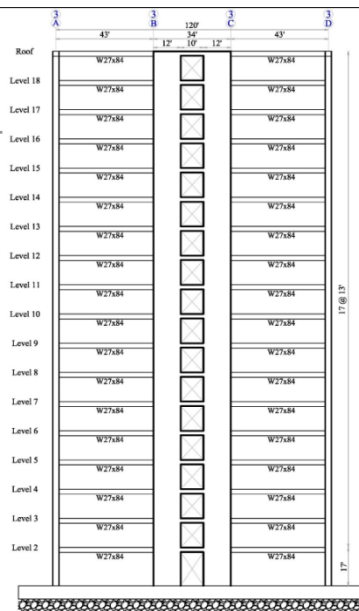

Figure 5. Section View of Coupled C-PSW/CF and Steel Gravity Frames on Gridline 3

5.3 General Information of the Considered Building

5.3.1 MATERIAL PROPERTIES

ASTM A572 Grade 50 steel (steel plates), ASTM A992 Grade 50 steel (wide flange sections), and self-compacting concrete (SCC) are used in the design of this 18-story building. SCC has a flowability from 19 in. to 30 in., which is measured by a slump flow test. SCC is typically used for the construction of the C-PSW/CF system, as it has a good segregation resistance and does not require vibration. The material properties are as follows:

Material Properties

Steel:

- ASTM A572 Grade 50 steel (steel plates) & ASTM A992 Grade 50 steel (wide flange sections)
- $F_y = 50$ ksi
- $F_u = 65$ ksi
- $E_s = 29,000$ ksi
- $G_s = 11,500$ ksi
- $R_y = 1.1$ (ANSI/AISC 341-22 Table A3.1)

Concrete:

- Self-compacting concrete (SCC)
- $f'_c = 6$ ksi
- $E_c = 4,500$ ksi
- $G_c = 1,770$ ksi
- $R_c = 1.5$ (ANSI/AISC 341-16 H5-5)

5.3.2 LOADS

In addition to the self-weight of structure (gravity frames and core walls), the following loads are considered:

Floor live load = 50 psf (reducible)

Partition = 15 psf

Superimposed dead load (ceiling and floor finish) = 15 psf

Curtain wall = 15 psf (wall surface area)

5.3.3 LOAD COMBINATIONS

For the considered structure, load combinations provided in Chapter 2 of ASCE/SEI 7-22 are considered.

$1.4D$

$1.2D + 1.6L$ (or $0.5L_r$)

$1.2D + 0.5L \pm 1.0E$

$0.9D \pm 1.0E$

5.3.4. BUILDING SEISMIC WEIGHT

A 3D computer model of the building was developed using the ETABS software program, as shown in Figure 6, for the design of steel gravity frames. Based on the preliminary design of gravity frames, as shown in Figure 4, the self-weight of structure is calculated. Building seismic weight is calculated as follows.

First Story

Gravity frames (columns, beams, girders, composite slab, etc.) and C-PSW/CFs	= 1,276 kips
Superimposed dead load	= 180 kips
Curtain wall	= 99 kips
Total weight	= 1,555 kips

Typical Story

Gravity frames (columns, beams, girders, composite slab, etc.) and C-PSW/CFs	= 1,174 kips
Superimposed dead load	= 180 kips
Curtain wall	= 86 kips
Total weight	= 1,440 kips

Roof

Gravity frames (columns, beams, girders, composite slab, etc.) and C-PSW/CFs	= 999 kips
Superimposed dead load	= 180 kips
Curtain wall, including parapet	= 54 kips
Total weight	= 1,263 kips

Total seismic weight of the building is 25,855 kips.

- 3D computer model of the building was developed using a commercial software program for the design of steel gravity frames.
- Based on the preliminary design of gravity frames, the self-weight of structure is calculated.

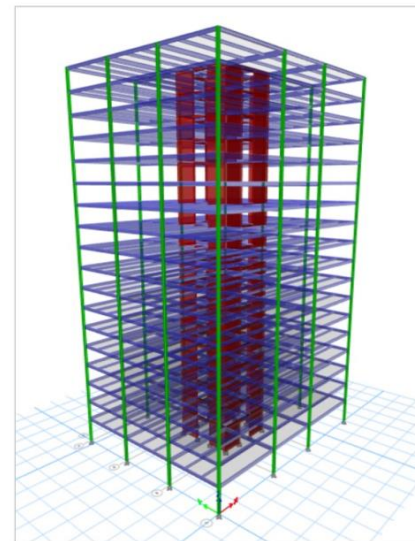

Figure 6. 3-D View of ETABS Model Used for Designing Steel Gravity Frames

5.3.5 SEISMIC DESIGN PARAMETERS

The seismic design parameters of this example are as follows:

$$S_{DS} = 1.101g$$

$$S_{D1} = 0.650g$$

Site Class D

Seismic Importance Factor, $I_e = 1.0$ (Risk Category II)

Seismic Design Category D

Coupled C-PSW/CFs are used in both directions to resist seismic loads, as shown in Figure 5-4. The seismic redundancy factor (ρ) is 1.0 (ASCE/SEI 7-22 Section 12.3.4.2). In accordance with the 2020 Edition of the *NEHRP Recommended Seismic Provisions* and upcoming ASCE/SEI 7-22, the proposed response modification factor (R), deflection amplification factor (C_d), and over-strength factor (Ω_o) for a coupled C-PSW/CF are following:

$$R = 8$$

$$\Omega_o = 2.5$$

$$C_d = 5.5$$

$$\rho = 1$$

In seismic design, ASCE/SEI 7-22 requires considering the accidental torsion in each direction when the building has a horizontal irregularity. In this design example, no accidental torsion and eccentricity are present in the structure; therefore, the seismic design of the coupled C-PSW/CF was performed without including accidental eccentricity.

5.3.6 SEISMIC FORCES

The period of the structure is calculated according to Section 12.8.2 of ASCE 7 standard. The approximate fundamental period of the structure is calculated as 1.21 seconds, shown below, using the “all other structural systems” category

Period of the structure

- $T_a = C_t h_n^x = (0.020) (238 \text{ ft})^{0.75} = 1.21 \text{ seconds}$
- $C_u = 1.4$ (ASCE/SEI 7 Table 12.8-1)
- $T = C_u T_a = (1.4) (1.21) = 1.70 \text{ seconds}$
- $T = 1.87$ (3D ETABS model)
- The period of structure is considered to be the upper limit, $C_u T_a = 1.70$

The period of the structure is also estimated using a detailed 3D computer model developed in ETABS software program. The computed period of 3D ETABS model is 1.87 seconds, which is higher

than the upper limit. Therefore, the period of the structure is considered to be the upper limit, $C_u T_a = 1.70$ seconds, for the calculation of seismic forces.

There are no irregularities along the height of the structure, and the building floor plan is symmetric. In this example, the Equivalent Lateral Forces (ELF) procedure was used to calculate the seismic loads. The design base shear of the building is calculated using ASCE/SEI 7-22 Equation 12.8-1, where W is the total seismic weight calculated in Section 5.5.3.4 0. The calculations of ELF for the considered building are illustrated as follows:

$$V = C_s W \quad (\text{ASCE/SEI 7-22 Eq. 12.8-1})$$

Seismic response coefficient, C_s , is estimated according to ASCE/SEI 7-22 Section 12.8.1.1.

$$C_s = \frac{S_{DS}}{R/I_e} = \frac{1.101}{8/1} = 0.138 \quad (\text{ASCE/SEI 7-22 Eq. 12.8-2})$$

$$C_{s,Max} = \frac{S_{D1}}{T(R/I_e)} = \frac{0.65}{1.7(8/1)} = 0.048 \quad (\text{ASCE/SEI 7-22 Eq. 12.8-3})$$

$$C_{s,Min} = 0.44 S_{DS} I_e = (0.44)(1.101)(1) = 0.048 \quad (\text{ASCE/SEI 7-22 Eq. 12.8-5})$$

$$C_{s,Max} = \frac{0.5 S_1}{(R/I_e)} = \frac{(0.5)(0.650)}{(8/1)} = 0.041 \quad (\text{ASCE/SEI 7-22 Eq. 12.8-6})$$

Seismic Forces

Building Seismic Weight:

- First Story = 1,555 kips
- Typical Story = 1,440 kips
- Roof = 1,263 kips

Seismic Design Parameters:

- $S_{DS} = 1.101g$
- $S_{D1} = 0.650g$
- Site Class D
- Risk Category II
- Seismic Design Category D

Period of the structure

- $T_a = C_t h_n^x = (0.020) (238 \text{ ft})^{0.75} = 1.21$ seconds
- $C_u = 1.4$ (ASCE/SEI 7 Table 12.8-1)
- $T = C_u T_a = (1.4) (1.21) = 1.70$ seconds
- $T = 1.87$ (3D ETABS model)
- The period of structure is considered to be the upper limit, $C_u T_a = 1.70$

The seismic response coefficient that governs is 0.048 from Eq. 12.8-3, and this matches the minimum value from Eq. 12.8-5, and the design base shear is calculated to be 1,238 kips.

$$V = C_s W = (0.048) (25,844) = 1,238 \text{ kips}$$

ASCE/SEI 7-22 Equations 12.8-11 and 12.8-12 are used for the vertical distribution of seismic forces, as shown below, where k is determined to be 1.6 using linear interpolation in accordance with ASCE/SEI 7-22 Section 12.8.3.

$$F_x = C_{vx} V \quad (\text{ASCE/SEI 7-22 Eq. 12.8-11})$$

$$C_{vx} = \frac{W_x h_x^k}{\sum_{i=1}^n W_i h_i^k} \quad (\text{ASCE/SEI 7-22 Eq. 12.8-12})$$

$$k = 1.6 \quad (\text{ASCE/SEI 7-22 Section 12.8.3})$$

$$OTM = \sum_{i=1}^n F_i h_i$$

Lateral seismic forces, shears and overturning moment (OTM) are shown in Table 4. The overturning moment (OTM) of the building is computed 217217 kip-ft.

Design Base Shear

Equivalent Lateral Forces (ELF) procedure was used to calculate the seismic loads:

- $V = C_s W$
- $C_s = \frac{S_{DS}}{R/I_e} = \frac{1.101}{8/1} = 0.138 \quad (\text{ASCE/SEI 7 12.8-2})$
- $C_{s,Max} = \frac{S_{DS}}{T(R/I_e)} = \frac{1.101}{1.7(8/1)} = \mathbf{0.048} \quad (\text{ASCE/SEI 7 12.8-3})$
- $C_{s,Min} = 0.44 S_{DS} I_e = (0.44)(1.101)(1) = 0.048 \quad (\text{ASCE/SEI 7 12.8-5})$
- $C_s = \frac{0.5 S_1}{(R/I_e)} = \frac{(0.5)(0.65)}{(8/1)} = \mathbf{0.041} \quad (\text{ASCE/SEI 7 12.8-6})$
- $V = C_s W = \mathbf{(0.048) (25844) = 1,238 \text{ kips}}$
- $OTM = \sum_{i=1}^n F_i h_i = \mathbf{217,217 \text{ kip-ft}}$

Table 4. Vertical Distribution of Seismic Forces

Level	Elevation (ft.)	Weight (kips)	Wh^k (kip-ft)	C_{vx}	F_x (kips)	V_x (kips)	OTM (kip-ft)
Roof	238	1,263	7,941,532	0.118	146.2	146.2	34,788
Level 18	225	1,440	8,276,512	0.123	152.3	298.5	34,275
Level 17	212	1,440	7,525,512	0.112	138.5	437	29,364
Level 16	199	1,440	6,801,579	0.101	125.2	562.2	24,912
Level 15	186	1,440	6,105,409	0.091	112.4	674.6	20,901
Level 14	173	1,440	5,437,767	0.081	100.1	774.7	17,315
Level 13	160	1,440	4,799,497	0.071	88.3	863	14,134
Level 12	147	1,440	4,191,536	0.062	77.1	940.1	11,341
Level 11	134	1,440	3,614,936	0.054	66.5	1,006.7	8,916
Level 10	121	1,440	3,070,888	0.046	56.5	1,063.2	6,839
Level 9	108	1,440	2,560,756	0.038	47.1	1,110.3	5,090
Level 8	95	1,440	2,086,130	0.031	38.4	1,148.7	3,648
Level 7	82	1,440	1,648,895	0.025	30.3	1,179.1	2,489
Level 6	69	1,440	1,251,340	0.019	23	1,202.1	1,589
Level 5	56	1,440	896,334	0.013	16.5	1,218.6	924
Level 4	43	1,440	587,639	0.009	10.8	1,229.4	465
Level 3	30	1,440	330,535	0.005	6.1	1,235.5	183
Level 2	17	1,555	144,016	0.002	2.7	1,238.2	45
SUM	-	25,855	67,270,814	1	1,238		217,217

5.4 Structural Analysis (Seismic Design)

5.4.1 C-PSW/CFS AND COUPLING BEAM SECTION

Sizes of L-shaped C-PSW/CFs and coupling beams are selected based on the initial estimates of lateral loads. C-PSW/CFs and coupling beam sizes are optimized through iteration. Figure 5-7 shows selected core wall cross section dimensions. In this example, the selected sizes for L-shaped C-PSW/CFs and rectangular composite coupling beams are acceptable designed dimensions; therefore, the following sections illustrate the limit state checks.

L-shape C-PSW/CFs have length (L_w) of 12 feet and wall thicknesses (t_{sc}) of 16 in. Steel plate (t_p) and concrete (t_c) thicknesses are $\frac{1}{2}$ in., and 15 in., respectively. Composite coupling beam width (b_{CB}) and height (h_{CB}) are 16 and 24 in., respectively. Coupling beam flange ($t_{CB,f}$) and web ($t_{CB,w}$) plate thicknesses are $\frac{1}{2}$ and $\frac{3}{8}$ in., respectively.

L-shape C-PSW/CFs

$L_w = 12$ ft
 $t_{sc} = 16$ in.
 $t_p = \frac{1}{2}$ in.

Coupling beams

$L_{CB} = 10$ ft
 $b_{CB} = 16$ in.
 $h_{CB} = 24$ in.
 $t_{CB,f} = \frac{1}{2}$ in.
 $t_{CB,w} = \frac{3}{8}$ in.

C-PSW/CFs and Coupling Beam Dimensions

C-PSW/CF:

- $L_w = 12$ ft
- $t_{sc} = 16$ in.
- $t_p = \frac{1}{2}$ in.

Coupling beams:

- $L_{CB} = 10$ ft
- $b_{CB} = 16$ in.
- $h_{CB} = 24$ in.
- $t_{CB,f} = \frac{1}{2}$ in.
- $t_{CB,w} = \frac{3}{8}$ in.
- $L_{CB} / h_{CB} = 5$

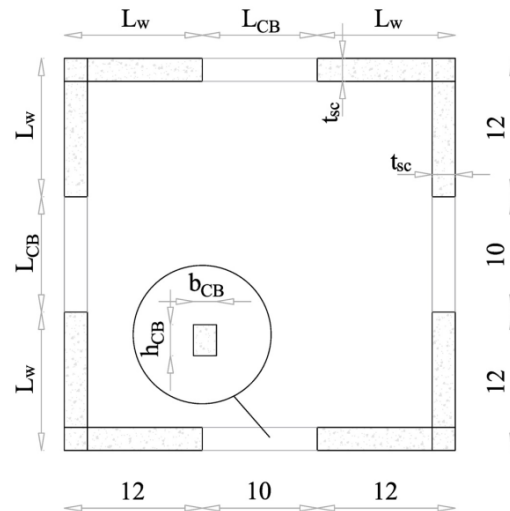

Figure 7. Core Walls Plan Section Dimensions

5.4.2 NUMERICAL MODELING OF COUPLED C-PSW/CF

For seismic design, a 2D computer model of the coupled C-PSW/CF was developed using a commercial software program (SAP2000) to determine the interstory drift and shear force demands in coupling beams. Coupling beams and L-shaped C-PSW/CFs were modeled using beam elements. When the coupled C-PSW/CF, shown in Figure 5-8, is subjected to lateral seismic loads, two walls are in tension, and the other two walls are in compression due to the coupling action. In this example, the two compression or tension walls are considered one wall (beam element) in computer modeling and the limit state checks. Additionally, in the 2D computer model, flexural, axial, and shear stiffnesses of coupling beam are doubled to model the two beams.

Effective flexural, axial, and shear stiffnesses of C-PSW/CFs and coupling beams were used in the computational model. Effective flexural, axial, and shear stiffnesses of coupling beams were calculated according to ANSI/AISC 360-16. Effective flexural, axial, and shear stiffnesses of CPSW/CF are calculated per AISC Design Guide 37 (AISC, 2021) as follows:

$$EI_{eff} = E_s I_s + 0.35 E_c I_c$$

$$EA_{eff} = E_s A_s + 0.45 E_c A_c$$

$$GA_{v,eff} = G_s A_{s,wall} + G_c A_c$$

Figure 8 shows a 2D computer model of the coupled C-PSW/CF which is subjected to seismic loads calculated in the previous section. Additionally, based on a tributary area force distribution, axial dead and live loads on L-shaped C-PSW/CFs (tension or compression walls) are calculated and defined in the 2D computer model. Axial dead and live loads per wall pair for each story are as follows:

$A_{tri} = 2291.5 \text{ ft}^2$	(Tributary area of tension or compression walls)
$F_{tri,DL} = 275 \text{ kips}$	(Axial dead load)
$F_{tri,LL} = 115 \text{ kips}$	(Axial live load)

In the 2D computer model, the effective distance (L_{eff}) between centers of areas (elastic centroids) of L-shaped C-PSW/CFs are considered. The effective distance is calculated of 323.8 in. As shown in Figure 5-8, rigid links are considered at the ends of coupling beams to simulate the effect of wall length. Effective flexural, axial, and shear stiffnesses of L-shaped C-PSW/CFs and coupling beams are calculated as follows:

$$L_{eff} = 324 \text{ in.}$$

$$EI_{eff} = 6.17 \times 10^{10} \text{ kip-in}^2$$

$$EA_{eff} = 3.35 \times 10^7 \text{ kips}$$

$$GA_{v,eff} = 1.11 \times 10^7 \text{ kips}$$

$$0.64 EI_{eff,CS} = 5.92 \times 10^7 \text{ kip-in}^2$$

$$0.8 EA_{eff,CS} = 2.03 \times 10^8 \text{ kips}$$

$$GA_{v,eff,CS} = 8.32 \times 10^5 \text{ kips}$$

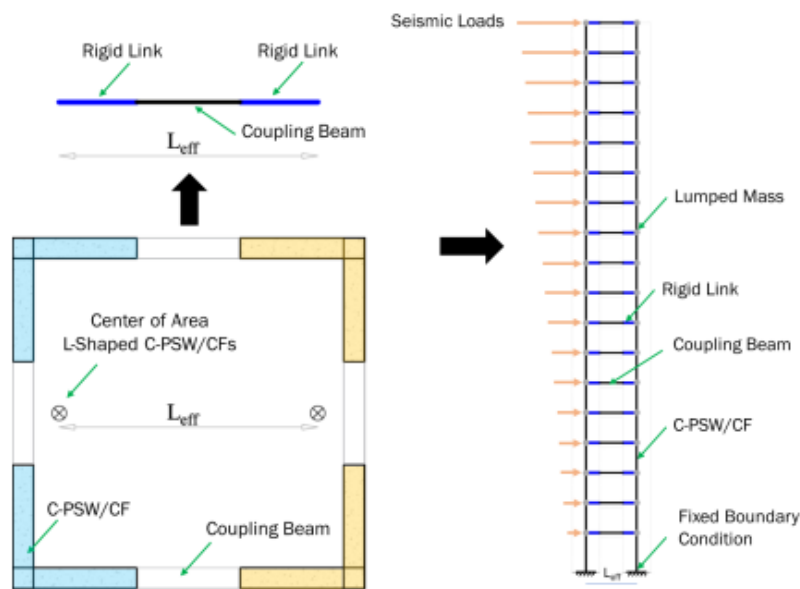

Figure 8. 2D Computer Modeling of Coupled C-PSW/CF Used in Seismic Design

Linear elastic analysis was performed to determine the lateral deflection and coupling beam shear force demands. Table 5-5 presents story displacement, amplified displacement, interstory drift, and coupling beam force shear demands. Amplified displacement is calculated by multiplying story displacement value by the deflection amplification factor, $C_d = 5.5$. Interstory drift is calculated using the amplified displacement. In this design example, the maximum design interstory drift is limited to 2% in accordance with ASCE/SEI 7-22 Table 12.12-1 as this is Risk Category II building, taller than four stories, and does not have a masonry seismic force-resisting system. From the structural analysis of the 2D model, the maximum interstory of the structure is 1.65%, which is lower than the maximum design interstory drift limit. Figure 5-9 shows deformation shape, lateral displacement, and interstory drift of the coupled C-PSW/CF. The deformed shape of the coupled C-PSW/CF shows the behavior of system is not similar to uncoupled C-PSE/CFs. In the uncoupled system, lateral forces are resisted by the flexural deformation of wall at the base; however, in the coupled system, lateral forces are resisted by both flexural deformation of individual walls at the base and coupling action. The colors in Figure 9a are associated with lateral displacements and correlate with the lateral displacement in Figure 9b.

Table 5. Vertical Distribution of Seismic Forces

Level	Story Elevation (ft.)	Displacement (in.)	Amplified Displacement (in.)	Interstory Drift (%)	Coupling Beam Shear Force Demand (kips)
Roof	238	6.95	38.24	1.32	89.2
Level 18	225	6.59	36.26	1.38	97.1
Level 17	212	6.22	34.20	1.44	110.2
Level 16	199	5.83	32.05	1.51	126.0
Level 15	186	5.42	29.80	1.56	129.4
Level 14	173	4.99	27.45	1.61	159.9
Level 13	160	4.55	25.01	1.64	176.0
Level 12	147	4.09	22.50	1.65	190.6
Level 11	134	3.63	19.94	1.65	203.1
Level 10	121	3.16	17.36	1.63	213.1
Level 9	108	2.69	14.79	1.57	220.1
Level 8	95	2.23	12.25	1.49	223.5
Level 7	82	1.78	9.81	1.38	222.4
Level 6	69	1.36	7.47	1.22	216.0
Level 5	56	0.97	5.33	1.02	202.8
Level 4	43	0.62	3.42	0.75	180.9
Level 3	30	0.33	1.83	0.33	147.5
Level 2	17	0.12	0.67	0.00	98.7
Average					167

Inter-story Drift Limit

- Deformation shape, lateral displacement, and inter-story drift.
- Amplified displacement is calculated by multiplying story displacement value by the deflection amplification factor. Inter-story drift is calculated using the amplified displacement.
- Maximum inter-story is 1.65%.

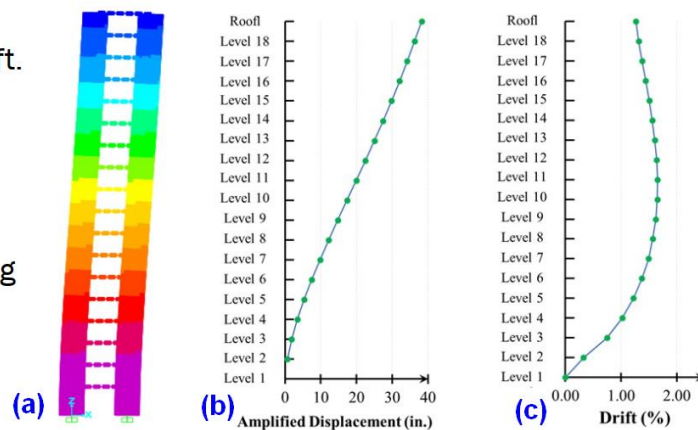

Figure 9. Coupled C-PSW/CF: (a) Deformation Shape from Computer Model, (b) Amplified Lateral Displacement, and (c) Interstory Drift

From the structural analysis of 2D model, the average and maximum required shear strengths ($V_{r,CB}$ and $V_{max,CB}$) for coupling beams are calculated. The average required shear strength is used to size the coupling beams. Structural designers can choose to use the average or maximum required shear strengths (AISC Design Guide 37). Since a portion of the OTM will be resisted by the coupling action and the remainder by the individual walls, the result of this choice is the relative proportioning of wall and coupling beam elements. Since the system is designed to ensure plasticity spreads along the height of the structure, either method is acceptable. The average and maximum required shear strengths for coupling beam are 167 and 223.5 kips, respectively. The average and maximum required flexural strengths ($M_{U,CB}$ and $M_{max,CB}$) for coupling beams are calculated at 835 and 1,117 kip-ft, respectively.

Linear Elastic Analysis

- $V_{r.CB} = 167$ kips (average)
- $V_{Max.CB} = 223.5$ kips (maximum)
- $M_{U.CB} = \frac{V_{r.CB} L_{CB}}{2} = 835$ kip-ft
- $M_{Max.CB} = \frac{V_{Max.CB} L_{CB}}{2} = 1,117$ kip-ft

(#)	Story Elevation (ft.)	Disp. (in.)	Amplified Disp. (in.)	Inter-story Drift (%)	CB Shear Force (kips)
Roof	238	6.95	38.24	1.32	89.2
Level 18	225	6.59	36.26	1.38	97.1
Level 17	212	6.22	34.20	1.44	110.2
Level 16	199	5.83	32.05	1.51	126.0
Level 15	186	5.42	29.80	1.56	129.4
Level 14	173	4.99	27.45	1.61	159.9
Level 13	160	4.55	25.01	1.64	176.0
Level 12	147	4.09	22.50	1.65	190.6
Level 11	134	3.63	19.94	1.65	203.1
Level 10	121	3.16	17.36	1.63	213.1
Level 9	108	2.69	14.79	1.57	220.1
Level 8	95	2.23	12.25	1.49	223.5
Level 7	82	1.78	9.81	1.38	222.4
Level 6	69	1.36	7.47	1.22	216.0
Level 5	56	0.97	5.33	1.02	202.8
Level 4	43	0.62	3.42	0.75	180.9
Level 3	30	0.33	1.83	0.33	147.5
Level 2	17	0.12	0.67	0.00	98.7

5.5. Design of Coupling Beams

Coupling beams are sized to meet the average required shear strength and provide adequate stiffness to meet the inter-story drift limit. This section presents design checks for coupling beams

5.5.1 FLEXURE-CRITICAL COUPLING BEAMS

Design Of Coupling Beams

Flexure-Critical Coupling Beams:

- $V_{n.exp.CB} \geq \frac{2.4 M_{p.exp.CB}}{L_{CB}}$ (AISC Design Guide 37, 2021)

Expected Flexural Capacity ($M_{p.exp.CB}$):

- $M_{p.exp.CB} = 1,582.6$ kip-ft

Minimum Area of Steel:

- $A_{s.CB.min} = 0.01 h_{CB} b_{CB} = (0.01)(24)(16) = 3.8 \text{ in.}^2$ (AISC Spec. I2.2a)
- $A_{s.CB} = 33.25 > A_{s.CB.min} = 3.8 \text{ in.}^2$

Coupling beams of the coupled C-PSW/CF system are designed to be a flexure critical member in accordance with ANSI/AISC 341-22 Section H8.5c. In this example, composite coupling beams of coupled L-shaped C-PSW/CFs are proportioned to be flexure critical members by controlling shear strength (AISC Design Guide 37), as shown below.

Where, $M_{p,Exp.CB}$ is expected flexural capacity of composite coupling beam. $V_{n,Exp.CB}$ is expected shear strength of composite coupling beam. L_{CB} is the clear length of composite coupling beam

5.5.2 EXPECTED FLEXURAL CAPACITY ($M_{P,EXP.CB}$)

The expected flexural capacity ($M_{p,Exp.CB}$) of coupling beam is calculated assuming the steel plate reaches a yield stress of $R_y F_y$ (in both compression and tension) and infill concrete reaches a yield stress of $R_c f'_c$ (in compression). Plastic stress distribution method is used to calculate expected flexural capacity ($M_{p,Exp.CB}$). The expected flexural capacity of the composite coupling beams is calculated as follows:

Width of concrete in composite coupling beam:

$$t_{c,CB} = b_{CB} - 2t_{CB,w} = 16 - 2(0.375) = 15.25 \text{ in.}$$

Plastic neutral axis of composite coupling beam:

$$C_{CB,exp} = \frac{2 t_{CB,w} b_{CB} R_y F_y + R_c 0.85 f'_c t_{c,CB} t_{CB,f}}{4 t_{CB,w} R_y F_y + R_c 0.85 f'_c t_{c,CB}} = 5.26 \text{ in.}$$

Compression (C) and tension (T) forces in coupling beam parts:

$$C_{1,exp} = (b_{CB} - 2t_{CB,w})t_{CB,f}R_y F_y = 419 \text{ kips} \quad (\text{Flange plate})$$

$$C_{2,exp} = 2t_{CB,w} C_{CB,exp} R_y F_y = 217 \text{ kips} \quad (\text{Web plates})$$

$$C_{3,exp} = R_c 0.85 f'_c t_{c,CB} (C_{CB,exp} - t_{CB,f}) = 556 \text{ kips} \quad (\text{Concrete})$$

$$T_{1,exp} = (b_{CB} - 2t_{CB,w})t_{CB,f}R_y F_y = 419 \text{ kips} \quad (\text{Flange plate})$$

$$T_{2,exp} = 2t_{CB,w}(h_{CB} - C_{CB,exp}) R_y F_y = 773 \text{ kips} \quad (\text{Web plates})$$

Expected flexural capacity of the composite coupling beams:

$$M_{p,Exp.CB} = C_{1,exp} \left(C_{CB,exp} - \frac{t_{CB,f}}{2} \right) + C_{2,exp} \left(\frac{C_{CB,exp}}{2} \right) + C_{3,exp} \left(\frac{C_{CB,exp} - 2t_{CB,f}}{2} \right) + T_{1,exp} \left(h_{CB} - C_{CB,exp} - \frac{2t_{CB,f}}{2} \right) + T_{2,exp} \left(\frac{h_{CB} - C_{CB,exp}}{2} \right) = 1,582.6 \text{ kip-ft}$$

$$M_{p,Exp.CB} = 1,582.6 \text{ kip-ft}$$

5.5.3 MINIMUM AREA OF STEEL

In accordance AISC 360 Section I2.2a, steel plates should comprise at least 1% of the total cross section area of composite coupling beam. Minimum area of steel in the composite coupling beam is checked as follows:

$$A_{s,CB,min} = 0.01 h_{CB} b_{CB} = (0.01)(24)(16) = 3.8 \text{ in.}^2 \quad (\text{AISC Spec. I2.2a})$$

$$A_{s,CB} = (2)(24)(0.375) + (2)(15.25)(0.5) = 33.25 \text{ in.}^2$$

$$A_{s,CB} = 33.25 \text{ in.}^2 > A_{s,CB,min} = 3.8 \text{ in.}^2$$

5.5.4 STEEL PLATE SLENDERNESS REQUIREMENT FOR COUPLING BEAMS

In seismic design of the coupled C-PSW/CF system, composite coupling beams are designed to be compact sections. The slenderness requirements of flange and web plates are checked in accordance with AISC 360-22 Section I1.4. Web plate slenderness requirement is established to develop the shear yielding of web plate before elastic shear buckling. The flange plate slenderness requirement is established to develop the compression yielding of the flange plate before elastic buckling.

Clear unsupported width and height:

$$b_{c,CB} = b_{CB} - 2t_{CB,w} = 16 - 2(0.375) = 15.25 \text{ in.}$$

$$h_{c,CB} = h_{CB} - 2t_{CB,f} = 24 - 2(0.5) = 23 \text{ in.}$$

Slenderness requirement for flange plates of coupling beam:

$$\frac{b_{c,CB}}{t_{CB,f}} = 30.5 < 2.37 \sqrt{\frac{E_s}{R_y F_y}} = 2.37 \sqrt{\frac{29000}{(1.1)(50)}} = 54.4 \quad (\text{AISC 360-22 Table I1.1b})$$

Slenderness requirement for web plates of coupling beam:

$$\frac{h_{c,CB}}{t_{CB,w}} = 61.3 \geq 2.66 \sqrt{\frac{E_s}{R_y F_y}} = 2.66 \sqrt{\frac{29000}{(1.1)(50)}} = 61.1 \quad (\text{AISC 360-22 Table I1.1b})$$

Although the ratio of $h_{c,CB} / t_{CB,w}$ is slightly higher than the slenderness requirement for web plates of coupling beam, in this design example, it is assumed the web plates of coupling beams meet the requirement.

5.5.5 FLEXURAL STRENGTH ($M_{p,CB}$)

The plastic stress distribution method is used to calculate flexural capacity ($M_{p,CB}$). The flexural capacity ($M_{p,CB}$) of coupling beam is calculated assuming the steel plate reaches a yield stress of F_y (in both compression and tension) and the infill concrete reaches a stress of $0.85f'_c$ (in compression). The flexural capacity of the composite coupling beam is calculated as follows:

Plastic neutral axis of composite coupling beam:

$$C_{CB} = \frac{2 t_{CB,w} b_{CB} F_y + 0.85 f'_c t_{c,CB} t_{CB,f}}{4 t_{CB,w} F_y + 0.85 f'_c t_{c,CB}} = 6.15 \text{ in.}$$

Compression (C) and tension (T) forces in coupling beam parts:

$$C_1 = (b_{CB} - 2t_{CB,w})t_{CB,f} F_y = 381 \text{ kips} \quad (\text{Flange plate})$$

$$C_2 = 2t_{CB,w} t_{CB,f} C_{CB} F_y = 230 \text{ kips} \quad (\text{Web plates})$$

$$C_3 = 0.85 f'_c t_{c,CB} (C_{CB} - t_{CB,f}) = 439 \text{ kips} \quad (\text{Concrete})$$

$$T_1 = (b_{CB} - 2t_{CB,w})t_{CB,f} F_y = 381 \text{ kips} \quad (\text{Flange plate})$$

$$T_2 = 2t_{CB,w}(h_{CB} - C_{CB}) F_y = 670 \text{ kips} \quad (\text{Web plates})$$

Design flexural capacity of the composite coupling beams:

$$M_{p,CB} = C_1 \left(C_{CB} - \frac{t_{CB,f}}{2} \right) + C_2 \left(\frac{C_{CB}}{2} \right) + C_3 \left(\frac{C_{CB} - 2t_{CB,f}}{2} \right) + T_1 \left(h_{CB} - C_{CB} - \frac{2t_{CB,f}}{2} \right) + T_2 \left(\frac{h_{CB} - C_{CB}}{2} \right) = 1,407 \text{ kip-ft}$$

$$M_{n,CB} = M_{p,CB} = 1,407 \text{ kip-ft}$$

$$\phi_b = 0.9$$

$$\phi_b M_{n,CB} = 1,266 \text{ kip-ft} > M_{U,CB} = 835 \text{ kip-ft}$$

Ratio of demand to capacity:

$$\frac{M_{r,CB}}{\phi_b M_{n,CB}} = \frac{835 \text{ kip-ft}}{1,266 \text{ kip-ft}} = 0.66$$

$$\frac{M_{U,CB}}{\phi_b M_{n,CB}} = \frac{1,117 \text{ kip-ft}}{1,266 \text{ kip-ft}} = 0.88$$

5.5.6 NOMINAL SHEAR STRENGTH (V_n .CB)

Nominal shear strength, V_n .CB, of composite coupling beam is calculated in accordance with AISC 360 Section I4.2. The nominal shear strength is the summation of shear strengths of steel web plates (V_s) and infill concrete (V_c).

Area of steel web plates

$$A_w.CB = 2h_{CB}t_{CB,w} = 2(24)(0.375) = 18 \text{ in.}^2$$

$$K_c = 1$$

(Compact cross section)

Nominal shear strength

$$V_{n,CB} = 0.6 F_y A_{w,CB} + 0.06 K_c \sqrt{f'_c} A_{c,CB} = (0.6)(50)(18) + (0.06)(1)(\sqrt{6})(15.25)(23)$$

$$V_{n,CB} = 592 \text{ kips}$$

$$\phi_v = 0.9$$

$$\phi_v V_{n,CB} = 532 \text{ kips} > V_{U,CB} = 167 \text{ kips}$$

Ratio of demand to capacity:

$$\frac{V_{U,CB}}{\phi_v V_{n,CB}} = \frac{167 \text{ kips}}{532 \text{ kips}} = 0.31$$

$$\frac{V_{U,CB}}{\phi_v V_{n,CB}} = \frac{223.5 \text{ kips}}{532 \text{ kips}} = 0.42$$

5.5.7 FLEXURE-CRITICAL COUPLING BEAMS (REVISITED)

The selected composite coupling beams are flexure critical members, as shown below

$$\begin{aligned} V_{n,exp,CB} &= 0.6 R_y F_y A_{w,CB} + 0.06 K_c \sqrt{R_c f'_c} A_{c,CB} \\ &= (0.6)(1.1)(50)(18) + (0.06)(1)(\sqrt{(1.5)(6)})(15.25)(23) = 657 \text{ kips} \end{aligned}$$

$$V_{n,exp,CB} = 657 \text{ kips} > \frac{2.4 M_{P,exp,CB}}{L_{CB}} = \frac{2.4 (1,582.6)}{10} = 380 \text{ kip}$$

5.6 Design of C-PSW/CF

L-shaped C-PSW/CFs are sized and designed based on the design philosophy of a strong wall-weak coupling beam approach. In accordance with this design approach, the formations of plastic hinges in most coupling beams take place along the height of the structure before significant yielding at the base of C-PSW/CFs. This section presents design checks for L-shaped C-PSW/CFs.

5.6.1 STEP 4-1: MINIMUM AND MAXIMUM AREA OF STEEL

In accordance with ANSI/AISC 360-22 Section I1.6, the steel plates in C-PSW/CFs should comprise at least 1% but no more than 10% of the total composite cross-section area. The selected cross section for L-shaped C-PSW/CF pair (compression or tension wall pair) meets the requirements for minimum and maximum steel plate areas, as shown below:

$$A_{gross.wall} = (2)[(L_w t_{sc}) + (L_w - t_{sc})t_{sc}] = 8,704 \text{ in.}^2$$

$$A_{s.min} = 0.01 A_{gross.wall} = (0.01)(8,704) = 87 \text{ in.}^2 \quad (\text{ANSI/AISC 360-22 I2.2a})$$

$$A_{s.max} = 0.1 A_{gross.wall} = (0.1)(8,704) = 870 \text{ in.}^2 \quad (\text{ANSI/AISC 360-22 I2.2a})$$

$$A_s = (t_p)[8L_w + 4t_{sc} - 16t_p] = 604 \text{ in.}^2$$

$$A_{s.min} = 87 \text{ in.}^2 < A_s = 604 \text{ in.}^2 < A_{s.max} = 870 \text{ in.}^2$$

5.6.2 STEEL PLATE SLENDERNESS REQUIREMENTS FOR COMPOSITE WALLS

In this design example, steel tie bars are only used in L-shaped C-PSW/CFs (no shear studs); therefore, the largest unsupported length between tie bars is considered for the slenderness requirements check. Tie bar spacings are selected 12 and 14 in. for the bottom (the bottom two stories) and top (remaining stories) of the L-shaped C-PSW/CFs. In accordance with ANSI/AISC 341-22 Chapter H8 Section 4b, steel plate slenderness ratio, b/t , at the base of C-PSW/CFs (protected zones) should be limited as follows:

$$S_{tie} = 12 \text{ in.} \quad (\text{The bottom two stories})$$

$$\frac{S_{tie}}{t_p} = 24 < 1.05 \sqrt{\frac{E_s}{R_y F_y}} = 1.05 \sqrt{\frac{29,000}{(1.1)(50)}} = 24.1 \quad (\text{ANSI/AISC 341-22 H8 Section 4b})$$

The steel plate slenderness ratio, b/t , at regions which are not protected zones should be limited as follows:

$$S_{tie.top} = 14 \text{ in.}$$

$$\frac{S_{tie.top}}{t_p} = 28 < 1.2 \sqrt{\frac{E_s}{F_y}} = 1.2 \sqrt{\frac{29,000}{(50)}} = 28.9 \quad (\text{ANSI/AISC 360-22})$$

It should be noted that the first slenderness check equation has R_y because it is the slenderness check for critical plastic zones (at the base of C-PSW/CFs), which is from AISC 341-22. In the seismic design of the coupled C-PSW/CF system, the critical plastic zones shall be highly ductile. The second slenderness check equation does not have R_y because it is the slenderness check for a portion of CPSW/CFs that does not undergo plastic response (as shown in Figure 5-3), which is from AISC 360-22.

5.6.3 TIE SPACING REQUIREMENTS FOR COMPOSITE WALLS

The stability of empty steel module of C-PSW/CF during the construction and concrete casting depends on tie bar spacing to plate thickness ratio (AISC Design Guide 37). Tie bars with $\frac{3}{4}$ diameters are selected for the L-shaped C-PSW/CFs, and the tie bar spacing to plate thickness ratio

is checked. In accordance with AISC 360 Section I1.6b, the tie bar spacing to plate thickness ratio, S/t_p , should be limited as follows:

$$d_{tie} = 3/4 \text{ in.}$$

$$\alpha = 1.7 \left(\frac{t_{sc}}{t_p} - 2 \right) \left(\frac{t_p}{d_{tie}} \right)^4 = 1.7 \left(\frac{16}{0.5} - 2 \right) \left(\frac{0.5}{0.75} \right)^4 = 10.07$$

$$\frac{S_{tie}}{t_p} = 24 < 1.0 \sqrt{\frac{E_s}{2\alpha + 1}} = 1.0 \sqrt{\frac{29,000}{2(10.07)+1}} = 37.0$$

$$\frac{S_{tie}}{t_p} = 32 < 1.0 \sqrt{\frac{E_s}{2\alpha + 1}} = 1.0 \sqrt{\frac{29,000}{2(10.07)+1}} = 37.0$$

5.6.4 REQUIRED WALL SHEAR STRENGTH

The base shear (V_{base}) associated with the seismic forces was calculated in Section 0. A shear amplification factor of 4 is used to amplify the base shear. The amplified shear force for the core walls is calculated as 4,952 kips. The required shear strength for tension or compression C-PSW/CFs ($V_{r.wall}$) is determined to be 2,476 kips, as the base shear are resisted by two wall pairs.

$$V_{Amplified} = 4,952 \text{ kips}$$

$$V_{r.wall} = \frac{4,952}{2} = 2,476 \text{ kips}$$

5.6.5 REQUIRED FLEXURAL STRENGTH OF COUPLED C-PSW/CF

In accordance with ASCE/SEI 7-22 and ANSI/AISC 341-22 Section H8.3d, in the coupled C-PSW/CF system, walls are designed for an amplified overturning moment (OTM). The overturning moment (OTM) is amplified by an amplification factor, γ_1 , which considers all coupling beams developing plastic hinges at both ends. The required amplified overturning moment (OTM) for designing the coupled C-PSW/CF system is calculated as follows:

Expected flexural capacity of coupling beam:

$$M_{p.exp.CB} = 1,583 \text{ kip-ft}$$

Expected shear strength of coupling beam:

$$V_{n.Mp.exp.CB} = \frac{(1.1)(1.1)(2) M_{p.exp.CB}}{L_{CB}} = \frac{2.4 M_{p.exp.CB}}{L_{CB}} = 380 \text{ kips} \quad (\text{AISC Design Guide 37})$$

In the above equation, the first factor (1.1) is considered due to strain hardening and the second factor (1.1) is considered due to additional flexural capacity of composite coupling beam. The additional flexural capacity of composite coupling beam is because of biaxial stress state of tension flange.

In accordance with AISC Design Guide 37, overstrength amplification factor for designing of CPSW/CF is calculated as follows:

$$\gamma_1 = \frac{\sum_n (1.1)(1.1) M_{p.exp.CB}}{\sum_n M_{U.CB}} = \frac{\sum_n 1.2 M_{p.exp.CB}}{\sum_n M_{U.CB}} = \frac{(18)(1.2)(1,583)}{(18)(835)} = 2.27 \quad (\text{AISC Design Guide 37})$$

Axial force to C-PSW/CFs due to coupling action due to the seismic loads:

$$P_{CB} = 2 \sum_n V_{n.Mp.exp.CB} = 13,673 \text{ kips}$$

In accordance with AISC Design Guide 37, required amplified overturning moment (OTM) for designing coupled C-PSW/CFs is calculated as follows:

$$M_{r.wall} = \gamma_1 OTM - P_{CB} L_{eff} = (2.27)(217,217) - (13,673)(27) = 125,077 \text{ kip-ft}$$

The effect of axial compression or tension force on C-PSW/CFs should be considered in the calculation of the flexural capacity of the wall. Maximum axial compression and tension forces on the compression and tension L-shaped C-PSW/CFs are calculated as follows: Maximum axial compression force to compression C-PSW/CFs considering the load combination of $1.2D+0.5L+E$:

$$P = -2 \sum_n V_{n.Mp.Exp.CB} - (1.2 \sum_n F_{Tri.DL}) - (0.5 \sum_n F_{Tri.LL}) = -20,644 \text{ kips}$$

Maximum axial tension force to tension C-PSW/CFs considering the load combination of 0.9D±E:

$$T = 2 \sum_n V_{n.Mp.exp.CB} - (0.9 \sum_n F_{Tri.DL}) = 9,219 \text{ kips}$$

“P” and “T” are calculated based on the design philosophy shown in Figure 3, and $F_{Tri.LL}$ and $F_{Tri.DL}$ were calculated in Section 5.5.4.2. In the seismic design of coupled C-PSW/CFs, maximum axial compression and maximum axial tension forces are “P” and “T” of the coupled C-PSW/CF system, as shown in Figure 1.

5.6.6 COMPOSITE WALL RESISTANCE FACTOR

Shear, flexure, compression, and tension resistance factors for composite wall are as follows:

ϕ_v	=	0.9	(ANSI/AISC 360-22 I4.1.a)
ϕ_b	=	0.9	(ANSI/AISC 360-22 I3.4b)
ϕ_c	=	0.9	(AISC Design Guide 37 Section 2.2.3)
$\phi_t = 0.9$			(AISC Design Guide 37 Section 2.2.3)

5.6.7. WALL TENSILE STRENGTH

Nominal tensile strength of two L-shaped C-PSW/CFs (tension walls) is calculated as follows:

$$A_s = 604 \text{ in}^2 \quad (\text{From Section 5.6.1})$$

$$P_{n.T} = A_s F_y = (604)(50) = 30,200 \text{ kips}$$

$$\phi_t P_{n.T} = 27,180 \text{ kips} > T = 9,219 \text{ kips}$$

$$\frac{T}{\phi_t P_{n.T}} = 0.35$$

5.6.8 WALL COMPRESSION STRENGTH

A simplified unit width method is considered to calculate nominal compression strength. This is a conservative approach to calculate the nominal compression strength, as the effect of end plates on the compression capacity is not considered. However, this simplified unit width method can be used for C-PSW/CFs with different configurations, for example, L-shaped, C-shaped, I-shaped walls. The selected unit width cross-section of the L-shaped C-PSW/CF is shown in Figure 10. The nominal compression strength of the L-shaped C-PSW/CF pair (compression walls) is calculated as follows:

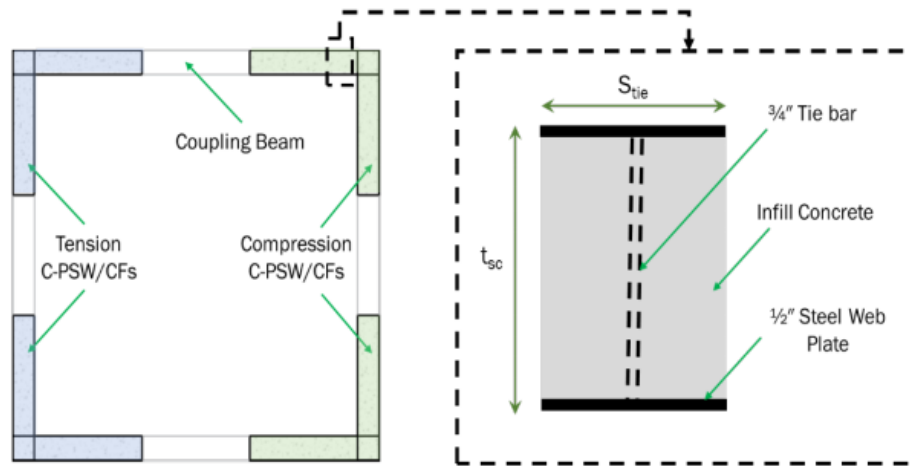

Figure 10. Unit Width Cross-section of L-shaped C-PSW/CF

$$\begin{aligned}
 S_{tie} &= 12 \text{ in} = 1 \text{ ft (Length of selected unit width)} \\
 L_{wall.total} &= 48 \text{ ft (Total length of two L-shaped C-PSW/CFs)} \\
 P_{no} &= 2t_p S_{tie} F_y + 0.85 f'_c (t_{sc} - 2t_p) S_{tie} = 1,518 \text{ kips} && \text{(ANSI/AISC 360-22)} \\
 I_{min.steel} &= 144 \text{ in}^4 \\
 I_{min.concrete} &= 2,160 \text{ in}^4 \\
 EI_{eff.min} &= E_s I_{min.steel} + 0.35 E_c I_{min.concrete} = 7,578,000 \text{ kip-in}^2 \\
 L_{cr} &= 17 \text{ ft (Critical unsupported length for buckling of wall)} \\
 P_e &= \frac{\pi^2 EI_{eff.min}}{L_{cr}^2} = 1797 \text{ kips} \\
 \frac{P_{no}}{P_e} &= 0.84 < 2.25 && \text{(ANSI/AISC 360-22)} \\
 P_{n.c} &= P_{no} \left(0.685 \frac{P_{no}}{P_e} \right) = 1,066 \text{ kips} \\
 n_{unit-width} &= \frac{L_{wall.total}}{S_{tie}} = \frac{48}{1} = 48 \\
 P_{n.c.total} &= P_{n.c} n_{unit-width} = (1,066 \text{ kips})(48) = 51,168 \text{ kips} \\
 \phi_C P_{n.c.total} &= (0.9)(51,168 \text{ kips}) = 46,051 \text{ kips} > P = 20,644 \text{ kips} \\
 \frac{P}{\phi_C P_{n.c.total}} &= 0.45
 \end{aligned}$$

For the wall subjected to axial compression force, a better estimate of minimum effective flexural stiffness ($EI_{eff.min}$) to calculate compression capacity is $EI_{eff.min} = E_s I_{min.steel} + 0.7 E_c I_{min.concrete}$. Using this estimate, the ratio of $P/\phi_c P_{n.c.total}$ becomes equal to 0.40. Even this calculation is quite conservative, as the (2L-shaped or C-shaped) wall section stiffness was not fully considered. Typically using $0.35 E_c I_{min.concrete}$ is corresponding to and for a member with zero axial compression force; however, $0.7 E_c I_{min.concrete}$ is approximately for a member with axial compression force, which results in less concrete cracking.

5.6.9 WALL FLEXURAL STRENGTH

Flexural capacity of the L-shaped C-PSW/CFs can be calculated using plastic stress distribution method or fiber section modeling, while the effect of axial force is considered (Shafaei et al., 2021b). When the core system is subjected to lateral seismic forces, two L-shaped C-PSW/CFs are subjected in tension force and the other two L-shaped C-PSW/CFs are in compression, as shown in Figure 11. The flexural capacities of tension and compression L-shaped C-PSW/CFs are calculated using plastic stress distribution method when they are subjected to -20,644 kips compression and 9,219 kips tension forces. In accordance with AISC Design Guide 37, the flexural capacities of compression and tension L-shaped C-PSW/CFs are calculated using the plastic stress distribution method as follows:

$$M_{P.T.wall} = M_{n.T.wall} = 1,598,236 \text{ kip-in.} = 133,186 \text{ kip-ft}$$

$$\phi_t M_{n.T.wall} = 1,438,412 \text{ kip-in.} = 119,868 \text{ kip-ft}$$

$$M_{P.C.wall} = M_{n.C.wall} = 1,761,166 \text{ kip-in.} = 146,764 \text{ kip-ft}$$

$$\phi_t M_{n.C.wall} = 1,585,050 \text{ kip-in.} = 132,088 \text{ kip-ft}$$

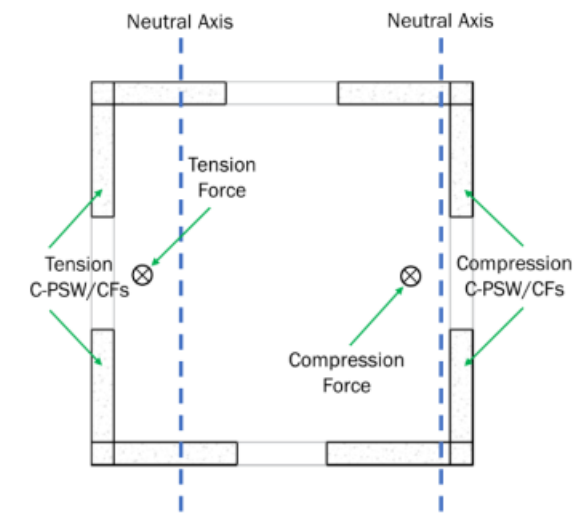

Figure 11. Cross-Section of Coupled L-shaped C-PSW/CF for Plastic Moment Calculation

Alternatively, the fiber section modeling can be used to calculate the moment-curvature responses and flexural capacities of tension and compression C-PSW/CFs. A fiber section model of L-shaped CPSW/CF was developed using “Section Designer” built into SAP2000 software. Figure 12 illustrates moment-curvature responses of tension and compression C-PSW/CFs. In addition, the flexural capacities calculated using the plastic stress distribution method are shown in the figure. The fiber section modeling and plastic stress distribution method estimate approximately the same flexural capacities. The flexural capacities of compression and tension L-shaped C-PSW/CFs are calculated using the fiber section modeling as follows:

$$M_{Max.T.wall.fiber} = 1,590,946 \text{ kip-in.} = 132,579 \text{ kip-ft}$$

$$M_{Max.C.wall.fiber} = 1,863,605 \text{ kip-in.} = 155,300 \text{ kip-ft}$$

$$\frac{M_{P.T.wall}}{M_{Max.T.wall.fiber}} = \frac{133,186 \text{ kip-ft}}{132,579 \text{ kip-ft}} = 1.00$$

$$\frac{M_{P.C.wall}}{M_{Max.C.wall.fiber}} = \frac{146,764 \text{ kip-ft}}{155,300 \text{ kip-ft}} = 0.94$$

The effective flexural stiffness (EI_{eff}) calculated in Section 5.4.2 did not consider the effect of tension or compression axial force. The effective flexural stiffness (EI_{eff}) of C-PSW/CFs subjected to axial force can be accurately estimated using the moment-curvature response. The effective flexural stiffness (EI_{eff}) of C-PSW/CFs was estimated as the secant stiffness corresponding to $0.6M_{Max.wall.fiber}$ on the moment-curvature response (Shafaei et al., 2021b). The effective flexural stiffness of tension and compression L-shaped C-PSW/CFs are estimated as follows:

$$EI_{T.wall} = 5.55 \times 10^{10} \text{ kip-in}^2$$

$$EI_{C.wall} = 7.21 \times 10^{10} \text{ kip-in}^2$$

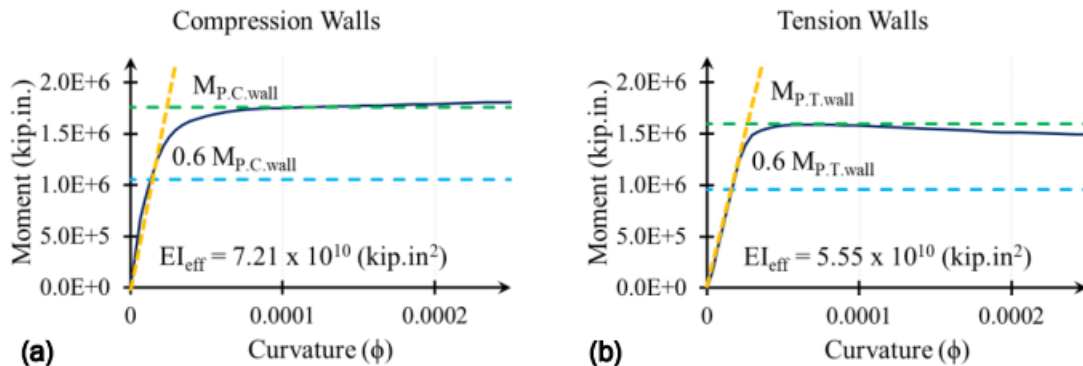

Figure 12. Moment-Curvature Response Developed by Fiber Section Analysis (a) Compression Walls (b) Tension Walls

The effective flexural stiffnesses of tension and compression ($EI_{T.wall}$ and $EI_{C.wall}$) L-shaped CPSW/CFs are used to calculate required flexural strengths of tension and compression walls.

$$M_{U.T.wall} = \left[\frac{EI_{T.wall}}{(EI_{C.wall} + EI_{T.wall})} \right] M_{r.wall} = 652,833 \text{ kip-in.} = 54,403 \text{ kip-ft}$$

$$M_{U.C.wall} = \left[\frac{EI_{C.wall}}{(EI_{C.wall} + EI_{T.wall})} \right] M_{r.wall} = 848,094 \text{ kip-in.} = 70,675 \text{ kip-ft}$$

Ratio of demand to capacity:

$$\frac{M_{U.T.wall}}{\phi_t M_{n.T.wall}} = \frac{54,403 \text{ kip-ft}}{119,868 \text{ kip-ft}} = 0.45$$

$$\frac{M_{U.C.wall}}{\phi_t M_{n.C.wall}} = \frac{70,675 \text{ kip-ft}}{132,088 \text{ kip-ft}} = 0.54$$

Alternatively, P-M interaction diagrams of tension and compression L-shaped C-PSW/CFs can be developed and compared with required flexural and axial strengths. The P-M interaction diagrams of C-PSW/CFs are calculated using either hand calculations or a software program. In this design example, the P-M interaction diagrams of the considered tension and compression L-shaped CPSW/CFs were developed using SAP2000. Figure 13 shows P-M interaction diagrams of tension and compression L-shaped C-PSW/CFs. As shown in the figure, L-shaped C-PSW/CFs can clearly resist the required axial (tension or compression) and flexural loads.

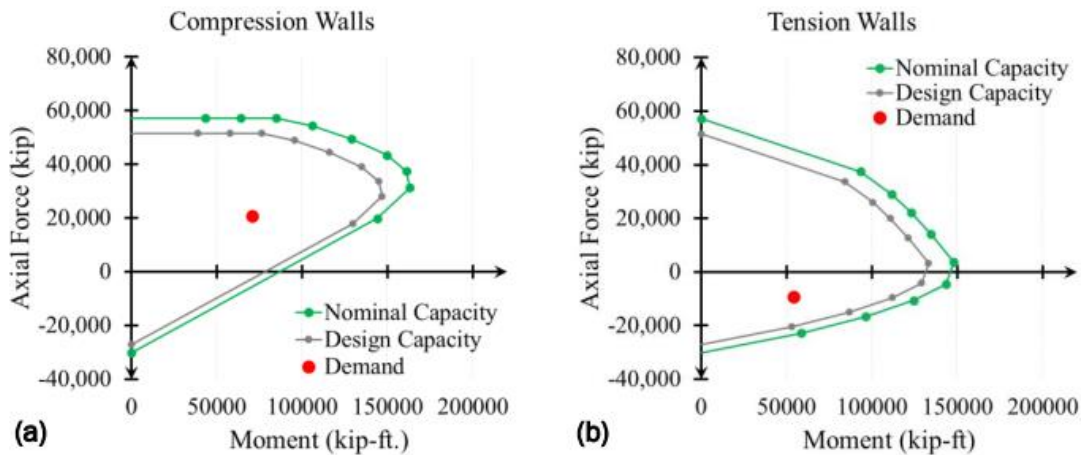

Figure 13. P-M Interaction of C-PSW/CFs (a) Compression Walls (b) Tension Walls

5.6.10 WALL SHEAR STRENGTH

In accordance with ANSI/AISC 341-22 Chapter H8 Section 6e, the nominal in-plane shear strength of L-shaped C-PSW/CFs is determined considering the steel section and infill concrete contributions as follows:

Area of steel in the direction of shear:

$$A_{s.wall} = 4(L_W t_p) + 2(t_{sc} t_p) = (4)(144)(0.5) + (2)(16)(0.5) = 304 \text{ in.}^2$$

K factor for shear strength calculation:

$$K_s = G_s A_{s.wall} = (11,200)(304) = 3.4 \times 10^6 \text{ kips}$$

$$K_{sc} = \frac{0.7(E_c A_c)(E_s A_{s.wall})}{(4E_s A_{s.wall}) + (E_c A_c)} = 3.14 \times 10^6 \text{ kips}$$

Nominal shear strength of C-PSW/CFs:

$$V_{n.wall} = \frac{K_s + K_{sc}}{\sqrt{3K_s^2 + K_{sc}^2}} A_{s.wall} F_y = 14,787 \text{ kips}$$

$$\phi_v V_{n.wall} = 13,308 \text{ kips} > V_{U.wall} = 2,476 \text{ kips}$$

Ratio of demand to capacity:

$$\frac{V_{U.wall}}{\phi_v V_{n.wall}} = 0.19$$

5.7 Coupling Beam Connection

There are several possible composite coupling beam-to-wall connections. In this design example, one possible coupling beam-to-wall connection is presented. Figures 14, 15, and 16 illustrate one possibility for coupling beam to wall connection details:

- As shown in Figure 14, there are slots in the C-PSW/CF web plates and coupling beam flange plates are inserted into the slots.
- Coupling beam flange plates are 1 in. wider than wall cross section from each side to provide adequate clearance for CJP welding, as shown in Figure 15.
- The slots of C-PSW/CF web plates are beveled and welded to the coupling beam flange plates using complete joint penetration (CJP) welding (as shown in Figure 15 and 16).
- The coupling beam web plates are overlapped the C-PSW/CF web plates and C-shaped fillet welding was done (as shown in Figures 15 and 16).
- The depth of coupling beam web plate is reduced 1 in. from top and bottom at the connection region to provide adequate clearance for fillet welding, as shown in Figures 5-14 and 5-15.

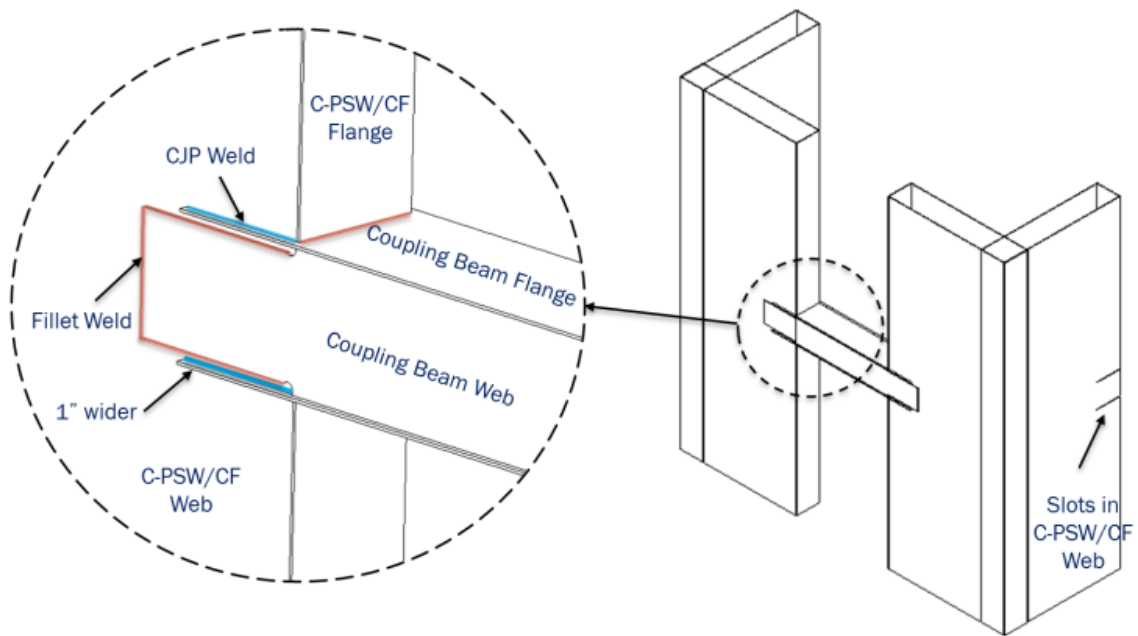

Figure 14. Schematic view of Coupling Beam-to-Wall Connection Details

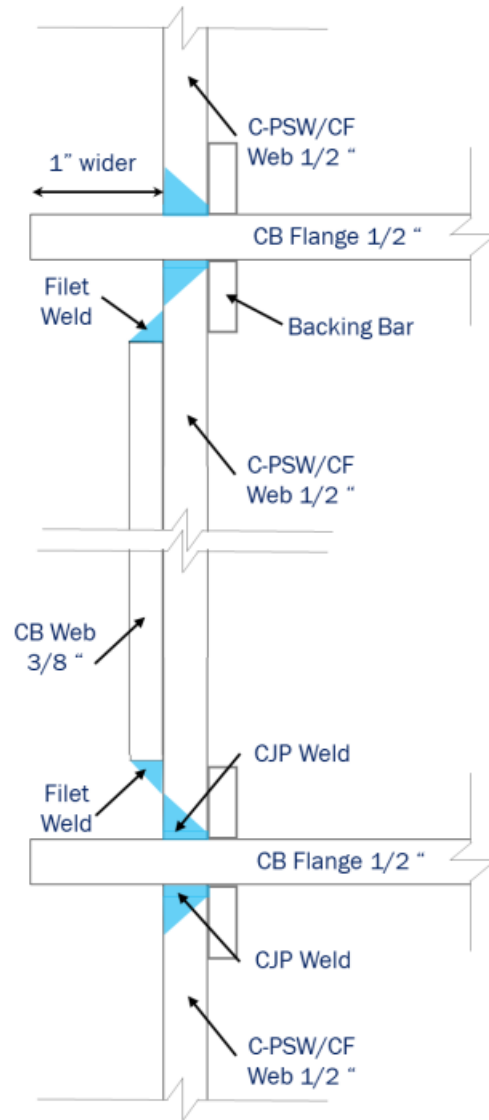

Figure 15. Schematic view of Coupling Beam-to-Wall Connection Details

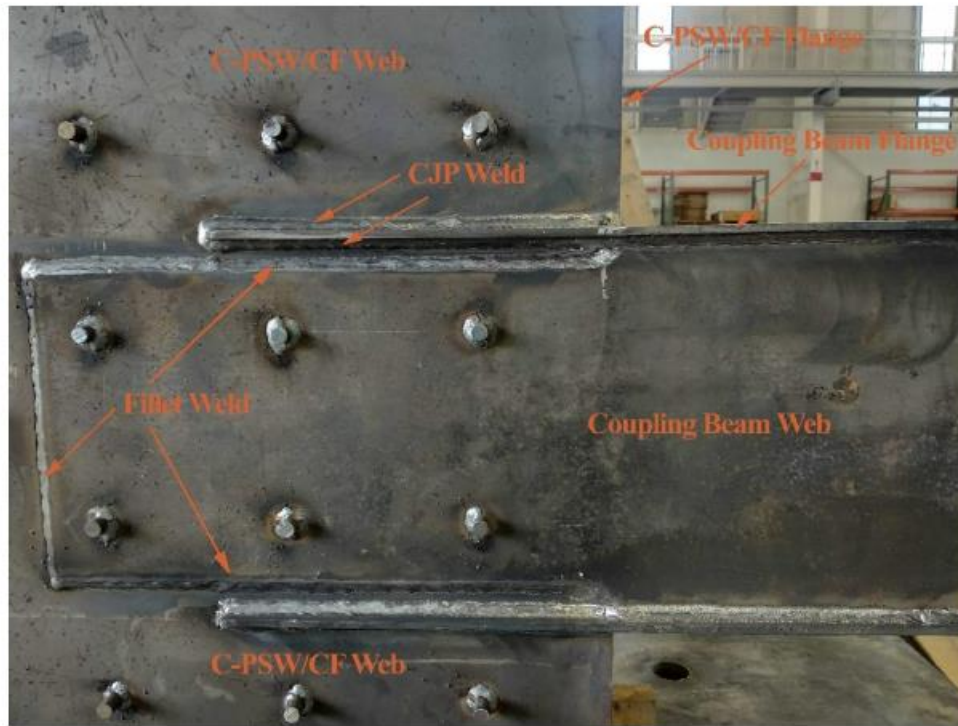

Figure 16. Coupling Beam-to-Wall Connection Details (Scaled Specimen Tested at Bowen Laboratory, Purdue University)

Note: The composite coupling beam cross section is changed due to the selection of this type of coupling beam-to-wall connection. The coupling beam flange plate width (b_{CB}) was previously designed to be 16 in. The coupling beam flange plate width is increased to 18 in. ($b_{CB} + 2$ in.) because of the connection details. In addition, the width of coupling beam is increased to 16.75 in. ($16" + 3/8" + 3/8"$) as well. The design of the coupled C-PSW/CF should be rechecked due to this cross section change. However, this section is only provided to show a design example of a possible coupling beam-to-wall connection; therefore, the rechecking is not shown here, and the original 16" width is used in the calculations.

The coupling beam to wall connection was designed for the expected coupling beam strength. AISC *Prequalified Connections for Special and Intermediate Steel Moment Frames for Seismic Applications* (AISC, 2016) recommends a similar approach for steel connections. In the design of this connection, ductile (yielding) and non-ductile (fracture) limit state factors are 1.0 and 0.9, respectively.

$$\phi_d = 1.0$$

$$\phi_n = 0.9$$

5.7.1 FLANGE PLATE CONNECTION DEMAND

Required strength for designing the coupling beam flange plate to C-PSW/CF connection is calculated as the minimum of (a) 1.2 times of the expected tensile strength of flange or (b) the expected tensile rupture strength of flange.

Area of flange plate:

$$A_{CB,f} = (b_{CB} + 2 \text{ in.}) t_{CB,f} = (16 + 2)(0.5) = 9 \text{ in.}^2$$

Required strength of flange plate connection:

$$R_t = 1.1 \quad (\text{Expected tensile strength factor, ANSI/AISC 360-16 Table A3.1})$$

$$T_{flange} = \min(1.2 R_y F_y A_{CB,f}, R_t F_u A_{CB,f})$$

$$T_{flange} = \min[(1.2)(1.1)(50)(9), (1.2)(65)(9)] = 594 \text{ kips}$$

$$\frac{T_{flange}}{2} = 297 \text{ kips}$$

5.7.2 CALCULATE REQUIRED LENGTH OF CJP WELDING

Required length for complete joint penetration (CJP) weld of the coupling beam flange plate to CPSW/CF connection is governed based on the coupling beam flange capacity as follows:

$$\frac{T_{flange}}{2} \leq \phi_d 0.6 F_y t_{CB.f} L_{req}$$

Required length of CJP weld:

$$L_{req.} \geq \frac{T_{flange}}{2(\phi_d 0.6 F_y t_{CB.f})} = \frac{594}{2(1.0)(0.6)(50)(0.5)} = 19.8 \text{ in.}$$

Length of CJP weld:

$$L_{weld.f} = 20 \text{ in.}$$

5.7.3 CHECK SHEAR STRENGTH OF COUPLING BEAM FLANGE PLATE

Shear yielding and shear rupture of coupling beam flange plate are calculated and compared with required strength of flange plate connection. Figure 5-17 shows the plane considered for the coupling beam flange plate shear yielding and shear rupture checks of this example.

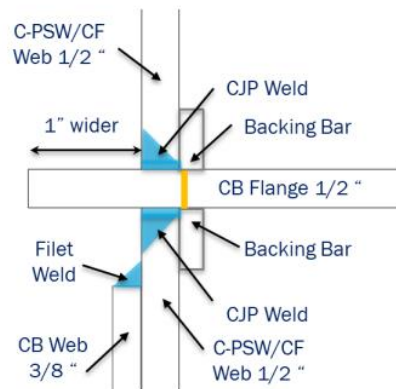

Figure 17. Shear Yielding and Shear Rupture of Coupling Beam Flange Plate

Gross shear area of coupling beam flange plate in shear yielding (the length along the CJP weld):

$$A_{f.SY} = t_{CB.f} L_{weld.f} = (0.5)(20) = 10 \text{ in.}^2$$

Shear yielding of coupling beam flange plate:

$$\phi_d 0.6 F_y A_{f.SY} = (1.0)(0.6)(50)(10) = 300 \text{ kips} \geq \frac{T_{flange}}{2} = 297 \text{ kips}$$

Net shear area of coupling beam flange plate in shear rupture (the length along the CJP weld):

$$A_{f.SR} = t_{CB.f} L_{weld.f} = (0.5)(20) = 10 \text{ in.}^2$$

Shear rupture of coupling beam flange plate:

$$\phi_n 0.6 F_u A_{f.SR} = (0.9)(0.6)(65)(10) = 351 \text{ kips} > \frac{T_{flange}}{2} = 297 \text{ kips}$$

5.7.4 CHECK SHEAR STRENGTH OF WALL WEB PLATES

Shear yielding and shear rupture of the C-PSW/CF web plate are calculated and compared with required strength of flange plate connection. Figure 5-18 shows planes considered for the C-PSW/CF web plate shear yielding and shear rupture checks of this example.

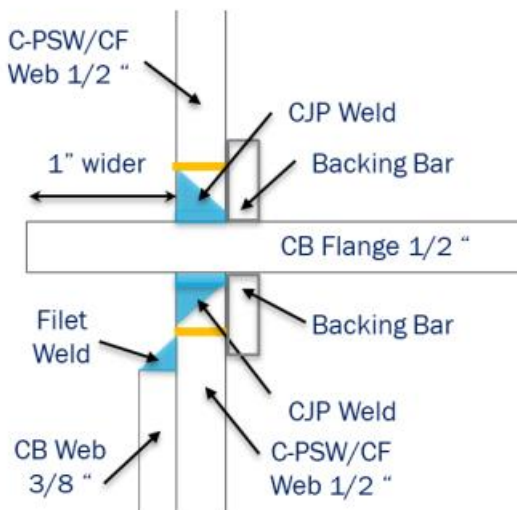

Figure 18. Shear Yielding and Shear Rupture of C-PSW/CF Web Plate

Gross shear area of C-PSW/CF web plate in shear yielding (the length along the CJP weld):

$$A_{w.SY} = 2 t_p L_{weld.f} = 2(0.5)(20) = 20 \text{ in.}^2$$

Shear yielding of C-PSW/CF web plate:

$$\phi_d 0.6 F_y A_{w.SY} = (1.0)(0.6)(50)(20) = 600 \text{ kips} > \frac{T_{flange}}{2} = 297 \text{ kips}$$

Net shear area of C-PSW/CF web plate in shear rupture (the length along the CJP weld):

$$A_{w.SR} = 2 t_p L_{weld.f} = 2(0.5)(20) = 20 \text{ in.}^2$$

Shear rupture of C-PSW/CF web plate:

$$\phi_n 0.6 F_u A_{w.SR} = (0.9)(0.6)(65)(20) = 702 \text{ kips} > \frac{T_{flange}}{2} = 297 \text{ kips}$$

5.7.5 CHECK DUCTILE BEHAVIOR OF FLANGE PLATES

In the coupling beam flange plate to C-PSW/CF connection design, the available tensile rupture strength should be higher than the available tensile yield strength.

Gross area of coupling beam flange plate in tension:

$$A_{CB.f.g} = (b_{CB} + 2in.) t_{CB.f} = (16 + 2)(0.5) = 9 \text{ in.}^2$$

Net area of coupling beam flange plate in tension:

$$A_{CB.f.n} = b_{CB} t_{CB.f} = (16)(0.5) = 8 \text{ in.}^2$$

Available tension yielding capacity of coupling beam flange plate:

$$R_y F_y A_{CB.f.g} = (1.1)(50)(9) = 495 \text{ kips}$$

Available tension rupture capacity of coupling beam flange plate:

$$R_t F_u A_{CB.f.n} = (1.2)(65)(8) = 624 \text{ kips}$$

$$R_t F_u A_{CB.f.n} = 624 \text{ kips} > R_y F_y A_{CB.f.g} = 495 \text{ kips}$$

The coupling beam flange plate connection (CJP welding) designed above transfers all coupling beam flange forces to the C-PSW/CF. The following sections present all the forces and eccentricities in the coupling beam web plates, which have to be transferred to the C-PSW/CF using fillet welding.

5.7.6 CALCULATE FORCES IN WEB PLATES

In coupling beam web plate to C-PSW/CF connection design, axial tension, shear force, and moment of coupling beam web plates are calculated as follows:

Expected tension force of coupling beam web plate (calculated in Section 5.5.2):

$$T_{2.exp} = 773 \text{ kips}$$

Expected compression force of coupling beam web plate (calculated in Section 5.5.2):

$$C_{2.exp} = 217 \text{ kips}$$

Plastic neutral axis of coupling beam considering expected strength (calculated in Section 5.5.2):

$$C_{CB.exp} = 5.26 \text{ in.}$$

Coupling beam web plates tension force:

$$T_{web} = 1.2 (T_{2.exp} - C_{2.exp}) = 667 \text{ kips}$$

Coupling beam web plates moment:

$$M_{web} = 1.2 \left(T_{2.exp} \frac{C_{CB.exp}}{2} + C_{2.exp} \frac{h_{CB} - C_{CB.exp}}{2} \right) = 407 \text{ kip-ft}$$

Coupling beam web plates shear force:

$$V_{web} = 2 \left(\frac{1.2 M_{p.exp.CB}}{L_{CB}} \right) = 380 \text{ kips}$$

5.7.7 CALCULATE FORCE DEMAND ON C-SHAPED WELD

The C-shaped fillet weld of the coupling beam web plate to C-PSW/CF connection is designed to resist simultaneous axial tension, shear force, and moment, as shown in Figure 19. It should be noted that, in Figure 19, the details of connection, coupling flange plates, CJP welding, C-PSW/CF web plate are not shown. Required forces for the design of the C-shaped fillet weld are as follows:

C-shaped weld required tension force:

$$T_{C.weld} = \frac{T_{web}}{2} = 333 \text{ kips}$$

C-shaped weld required moment:

$$M_{C.weld} = \frac{M_{web}}{2} = 203 \text{ kip-ft}$$

C-shaped weld required shear force:

$$V_{C.weld} = \frac{V_{web}}{2} = 190 \text{ kips}$$

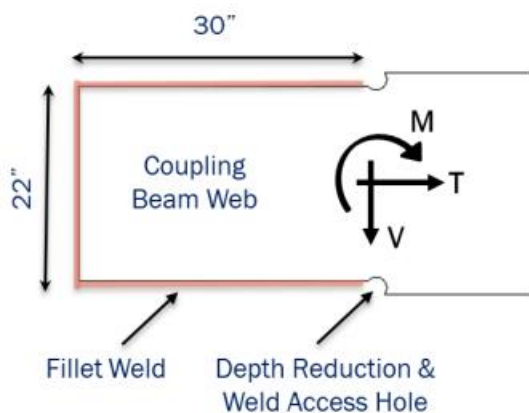

Figure 19. Required Forces for Designing the C-shaped Fillet Weld

5.7.8 SELECT WELD GEOMETRY

Vertical length of fillet weld:

$$L_{v.weld.w} = h_{CB} - 2 \text{ in.} = 22 \text{ in.}$$

Horizontal length of fillet weld:

$$L_{H.weld.w} = 30 \text{ in.}$$

Fillet weld minimum size:

$$D_{min} = 3/16 \text{ in.}$$

Fillet weld maximum size:

$$D_{max} = 5/16 \text{ in.}$$

Fillet weld maximum size is selected 5/16 in. because the coupling beam web plate thickness is 3/8 in:

Fillet weld size selected:

$$D = 5/16 \text{ in.}$$

$$D_{min} \leq D \leq D_{max}$$

5.7.9 CALCULATE C-SHAPED WELD SHEAR & MOMENT CAPACITIES

Instead of designing the C-shaped fillet weld of coupling beam web plate for simultaneous shear force and moment, it can be designed for an eccentric shear force, which produces an equivalent combined effect of shear force and moment. Therefore, the C-shaped fillet weld of coupling beam web plate is designed to resist simultaneous axial tension and eccentric shear force, as shown in Figure 20. This eccentrically loaded C-shaped fillet weld can be designed using AISC Steel Construction Manual, 15th Edition, Table 8 (AISC, 2017). The eccentrically loaded C-shaped fillet weld is designed as follows:

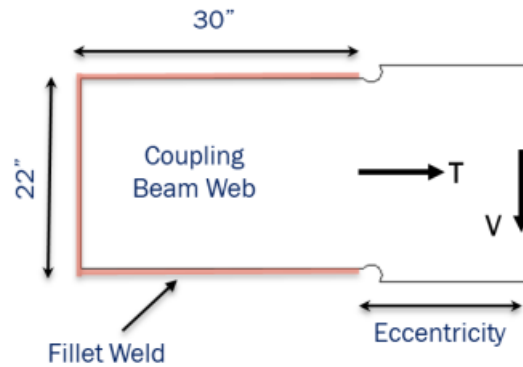

Figure 20. Required Tension and Eccentric Shear Forces for the Design of C-shaped Fillet Weld

$$Eccentricity = M_{C.web} / V_{C.web} = (203)(12) / 190 = 12.85 \text{ in.}$$

Centroid of C-shaped fillet weld (horizontal):

$$c.g. = \frac{L_{H.weld.w}^2}{2L_{H.weld.w} + L_{V.weld.w}} = \frac{30^2}{2(36) + (22)} = 10.98 \text{ in.}$$

Eccentricity of shear force from vertical fillet weld (horizontal):

$$e_x = \text{Eccentricity} + (L_{H.weld.w} - c.g.) = 12.9 + (30 - 11) = 31.88 \text{ in.}$$

Horizontal to vertical fillet weld length ratio:

$$k = \frac{L_{H.weld.w}}{L_{V.weld.w}} = \frac{30}{22} = 1.36$$

Eccentricity to vertical fillet weld length ratio:

$$a = \frac{e_x}{L_{V.weld.w}} = \frac{11}{22} = 1.45$$

$$C_{8.8} = 3.11 \quad (\text{AISC Steel Construction Manual, 15}^{\text{th}} \text{ Edition, Table 8-8})$$

$$C_{1-8.3} = 1 \quad (\text{AISC Steel Construction Manual, 15}^{\text{th}} \text{ Edition, Table 8-3})$$

In accordance with AISC Steel Construction Manual, 15th Edition, Table 8-8, fillet weld capacity to resist the eccentric shear force is as follows:

$$P_{V.weld} = \phi_n C_{8.8} C_{1-8.3} (16D) L_{V.weld.w} = (0.9)(2.99)(1) \left[16 \left(\frac{5}{16} \right) \right] (22) = 307 \text{ kips}$$

$$P_{V.weld} = 334 \text{ kips} > V_{C.weld} = 190 \text{ kips}$$

$$\frac{V_{C.weld}}{P_{V.weld}} = 0.62$$

5.7.10 CALCULATE C-SHAPED WELD TENSION CAPACITY

In accordance with ANSI/AISC 360-16 Section J2.4, tension (horizontal) capacity of C-shaped fillet weld is calculated as follows:

$$P_{T.weld} = \phi_n 0.6 F_{XX} 2 L_{H.weld.w} 0.7071D = (0.9)(0.6)(70)[2(30)](0.7071)(5/16)$$

$$P_{T.weld} = 501 \text{ kips} > T_{C.weld} = 333 \text{ kips}$$

$$\frac{T_{C.weld}}{P_{T.weld}} = 0.67$$

5.7.11 CALCULATE THE UTILIZATION OF C-SHAPED WELD CAPACITY

The utilization ratio of the C-shaped fillet weld is calculated by taking the square root of the sum of the squared utilization of the eccentric shear capacity and tension capacity.

$$Capacity = \sqrt{\left(\frac{V_{C.weld}}{P_{V.weld}}\right)^2 + \left(\frac{T_{C.weld}}{P_{T.weld}}\right)^2} = \sqrt{(0.62)^2 + (0.67)^2} = 0.91 \leq +1$$

Calculate Capacity of C-Shaped Weld

$$P_{T.weld} = \phi_n 0.6 F_{XX} 2 L_{H.weld.w} 0.7071D = (0.9)(0.6)(70)[2(30)](0.7071)(5/16)$$

$$P_{T.weld} = 501 \text{ kips} > T_{C.weld} = 333 \text{ kips}$$

$$\frac{T_{C.weld}}{P_{T.weld}} = 0.67$$

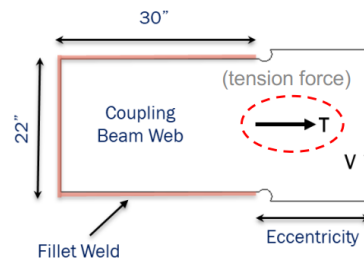

$$Capacity = \sqrt{\left(\frac{V_{C.weld}}{P_{V.weld}}\right)^2 + \left(\frac{T_{C.weld}}{P_{T.weld}}\right)^2} = \sqrt{(0.64)^2 + (0.67)^2} = 0.91 \leq 1$$

REFERENCES

- 1) ***FEMA P-2192-VI/November 2021 , Volume I: Design Examples , 2020 NEHRP Recommended Seismic Provisions: Design Examples, Training Materials, and Design Flow Charts , Federal Emergency Management Agency, FEMA.***