

*An Online PDH Course
brought to you by
CEDengineering.com*

Capacity Planning Fundamentals

Course No: K03-003

Credit: 3 PDH

Richard Grimes, MPA, CPT



Continuing Education and Development, Inc.

P: (877) 322-5800

info@cedengineering.com

www.cedengineering.com

Capacity Planning Fundamentals

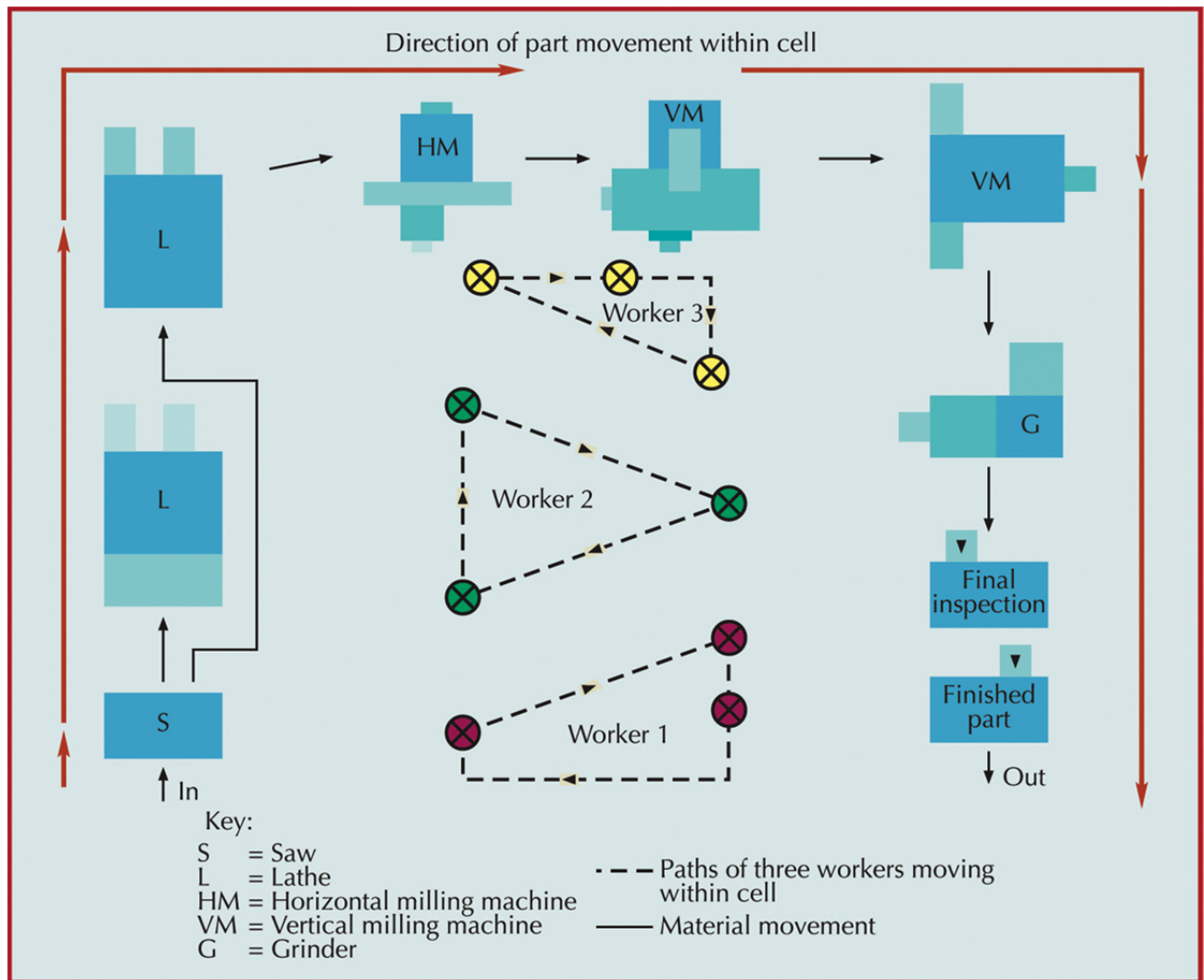

Table of Contents

Table of Contents.....	2
Overview	3
Learning Outcomes.....	3
Intended Audience	3
Concepts of Capacity	4
Laying Out the Facility	6
Types of Layouts	7
Process (or functional) Layouts	7
Product Layouts.....	9
Fixed Position Layouts.....	10
Designing Process Layouts.....	10
Block Diagramming.....	10
Relationship Diagramming.....	13
Designing Service Layouts	15
Designing Product Layouts.....	16
Designing With Precedence Considerations	25
Comments about the Workflow.....	29

Overview

Long term capacity planning is a strategic decision for a company that must be carefully researched before implementation. The placement of equipment and its related work and maintenance access, material and work flows, plus potential expansion is critical because plant design and construction are normally tied to it. Clearly, this is an example of form following function.

This course identifies the fundamental considerations associated with capacity planning so a student can converse more knowledgeably with plant designers, industrial engineers, and representatives of operations, procurement, human resources, and safety.

Learning Outcomes

Participants in this self-study course will learn to:

1. Analyze floor plans for optimal work flow
2. Analyze work flows to determine their current efficiency
3. Explain and apply the principles of 'line balancing'
4. Determine work process flow adequacy
5. Revise workflows to improve efficiency
6. Explain the concept of 'flow time'
7. Create optimal production cycle timing
8. Apply three capacity planning strategies effectively.
9. Apply the skills learned to practice exercises within the course

Intended Audience

This course is designed for project managers, operations managers and supervisors, human resource professionals, or anyone involved in the process of converting raw materials into finished products who want to have a fundamental understanding of the factors that influence planning the capacity of a production process. These products can also be finished documents and not only hardware or durable goods.

Concepts of Capacity

Capacity is about an organization's *capability of producing something*. Planning for this capacity typically happens at a variety of levels and detail. This course will focus on the basics essential to a fundamental understanding of the process.

An organization's capacity is *pulled* by customer demand (if they didn't want it, why would you make it?) and *pushed* by the receipt of raw materials from suppliers. In a perfect world, the demand would be constant, the supplies on time and in the exact quantities and quality we need, while our machines would hum along at peak efficiency. [Remember, also, that we are not just talking about the industrial world here: "production" also applies to assembling complex documents such as all the paperwork associated with buying a home, or serving customers at the drive up window of a fast food outlet.] Taking this a step farther, our customers would pay early and we would pay our providers (suppliers) at the last possible minute before incurring penalties so we can hold on to the cash as long as possible and maximize our cash flow.

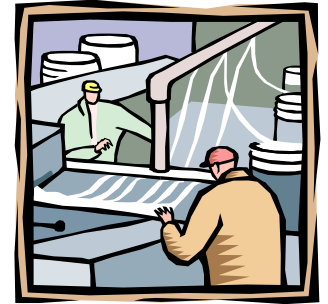

Unfortunately, this is not a perfect world and many factors can impact the ability of our assembly lines to hum along at peak efficiency. Companies who enjoy greater success in producing, selling, and delivering products focus on the demand side of the equation. *In other words, the more they can understand their customers' needs and meet them, the greater their success.* This is in contrast to companies who focus primarily on their suppliers by fighting hard for the best prices, quantities, qualities, and delivery dates.

Although it is certainly important to fight for the best prices, etc. from your supplier, it is only through a strong relationship with their customers that a producer can make sure they buy the right kinds of raw materials in the qualities and quantities they need to meet demand. It is surprising but true that many manufacturers have a lot of money tied up in inventory that is either obsolete or just not part of what customers are demanding currently. **They focus on what they have to sell instead of what their customers want to buy.**

We will begin our learning by looking at three strategies to plan capacity: *lead, average, and lagging*.

1. **Lead capacity strategy** – capacity is expanded in *anticipation* of a growth in demand. This anticipation may result from a marketing plan to lure customers away from another or by entering a market by offering special pricing or quantities. It also helps companies plan for anticipated surges in demand or to provide high levels of customer service during specific periods.

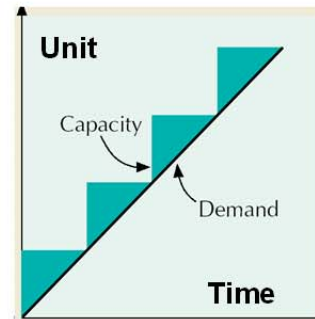

2. **Average capacity strategy** – we expand capacity to coincide with an *average of what we expect* knowing there will be times when we cannot meet all the demand as well as time when we have too much capacity for a lowered demand. We expect that about 50% of the time, capacity will lead demand and lag behind it at about 50%, too.

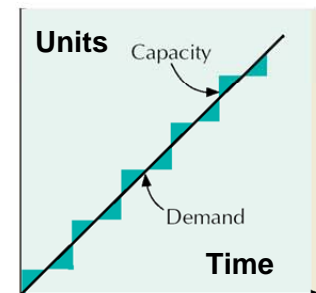

3. **Lagging capacity strategy** – capacity expands *after* an increase has been documented. Although customer service suffers initially, it assumes they will be back because there are few (if any) other places where they can obtain this product after our capacity has increased.

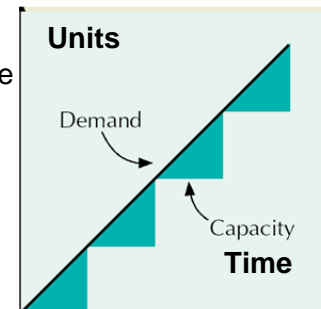

Once a capacity strategy is identified, then the extent of the increase is based upon:

- The volume and certainty of anticipated demand
- Strategic objectives in terms of customer service, anticipated growth, and anticipated competition
- The cost of anticipated expansion and operation to meet the company's strategy

We will address the issues of anticipating demand and production planning in the rest of this course.

How would these various strategies be used in higher education?

Suppose that a state is experiencing a large increase in population which means there will be a demand for higher education in just over a decade. This is how the three different strategies would be applied:



Think
about...

- An *established* university that is guaranteed applicants even in lean years may follow a **lag strategy**
- A *new university* may use a **lead strategy** to capture applicants who cannot get into the established university
- A community college may use the **average strategy** because there is little risk when considering its mission to admit all eligible applicants.

Laying Out the Facility

The art (or science depending on how you look at it) of laying out a facility has changed over the years because of changes in:

1. Our concepts of how to produce (do we keep extensive inventory on hand because we are supplier driven or small amounts -“just-in-time” - because we are customer focused);
2. What to produce (markets have changed in demand and location)
3. The constant evolution of technology plus a shrinking, ageing workforce can change our long-term strategy.

Some thinking associated with the machinery we will use or tasks we must complete should consider:

- Minimize material-handling costs
- Utilize space and labor efficiently
- Eliminate bottlenecks
- Facilitate communication and interaction between all involved
- Reduce manufacturing cycle time and customer service time
- Eliminate wasted or redundant movement
- Increase capacity (produce more, not just do more)
- Facilitate entry, exit, and placement of material, products, and people
- Incorporate safety and security measures
- Promote product and service quality
- Encourage proper maintenance activities
- Provide a visual control of activities and flexibility to adapt to changing conditions

Types of Layouts

We will look at three basic types of layouts. Please remember that capacity planning is not confined to just “making things”, *it is also relevant to customer service businesses and retail outlets where customers serve themselves.* The three most common examples are:

1. **Process (aka ‘functional’) layouts** - group similar activities together according to the process or function they perform
2. **Product layouts** - arrange activities in line according to sequence of operations for a particular product or service
3. **Fixed-position layouts** - are used for projects in which the product cannot be moved

Process (or functional) Layouts

This layout groups similar functions together. It may be thousands of different types of items in a do-it-yourself ‘big box’ store, types of clothing in a retail store that makes it easy for clerks or customers to find what they need by visiting different departments or a machine shop may group saws in one place, drills in another, and sanders in a third.

This layout is characteristic of intermittent operations where a wide variety of customers with wide-ranging needs are served. In a process layout, like a machine shop or automotive repair center, the equipment is general purpose and the workers are skilled at operating their machines in their departments or areas.

The advantage of this is flexibility and can meet customers’ needs easily and quickly but, since work doesn’t flow smoothly through it and may ‘backup’ from down-line stations, or cross the flow of other work, this is also a disadvantage.



Table 1 - Process Layout Summary

Characteristics	Application to a Process Layout
Description	Functional grouping of activities
Type of Process	Intermittent, job shop, batch production, mainly fabrication
Product	Varied, made to order
Demand	Fluctuating
Volume	Low
Equipment	Purpose
Workers	Varied skills - some potential for cross-functional working
Inventory	High in-process, low finished goods
Storage Space	Large
Materials Handling	Variable path (forklift)
Aisles	
Scheduling	Dynamic – varies with the demand
Layout Decision	Machine location
Goal	Minimize material handling cost
Advantage	Flexibility

Process Layout for a Retail Business



Process Layout for a Manufacturing Business

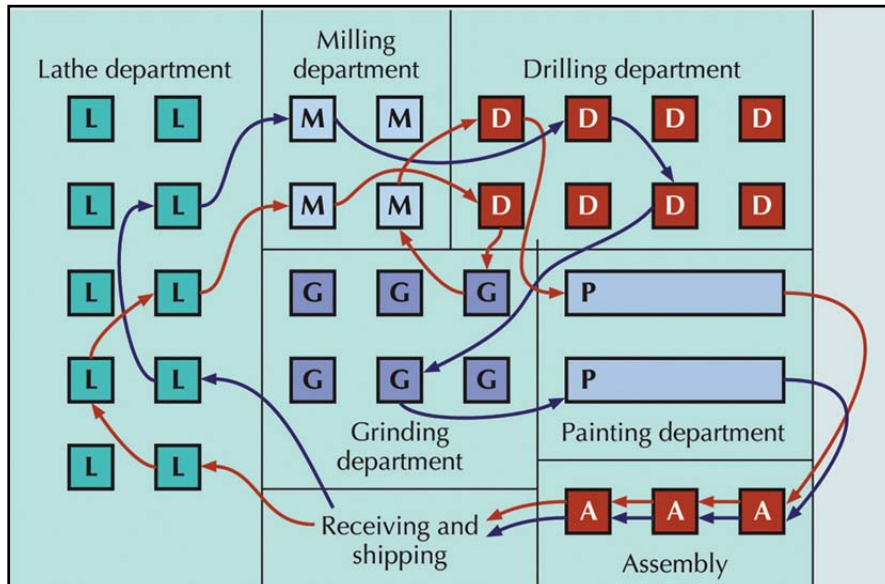

Product Layouts

Product layouts are better known as *assembly lines*. Henry Ford taught this to American industry when he demonstrated that a line of sequential events with each sub-assembly having its own line was a secret to mass production. (This assumes, of course, that materials flowed into the plant at about the same speed finished cars rolled out the other end.) The flow of work is orderly and efficient moving from one workstation to the next where the technicians wait to perform their specialty – whether welding the car frame or tightening a lug nut on a wheel.

Since the market for these products is very specific, dependable, stable, it makes economic sense to purchase large, immovable machines performing limited functions. The product made is a standardized one (not like a craftsman's single piece) and the volume is high.

Table 2 Product Layout

Characteristics	Application to a Product Layout
Description	Sequential arrangement of activities
Type of Process	Continuous, mass production, mainly assembly
Product	Standardized – made to stock
Demand	Stable
Volume	High
Equipment	Special Purpose
Workers	Limited skills - no cross functional work potential
Inventory	Low in-process, high finished goods
Storage Space	Small
Materials Handling	Fixed path (conveyor)
Aisles	Narrow
Scheduling	Stable - Varies with balancing and demand
Layout Decision	Line balancing
Goal	Equalize work at each station
Advantage	Efficiency

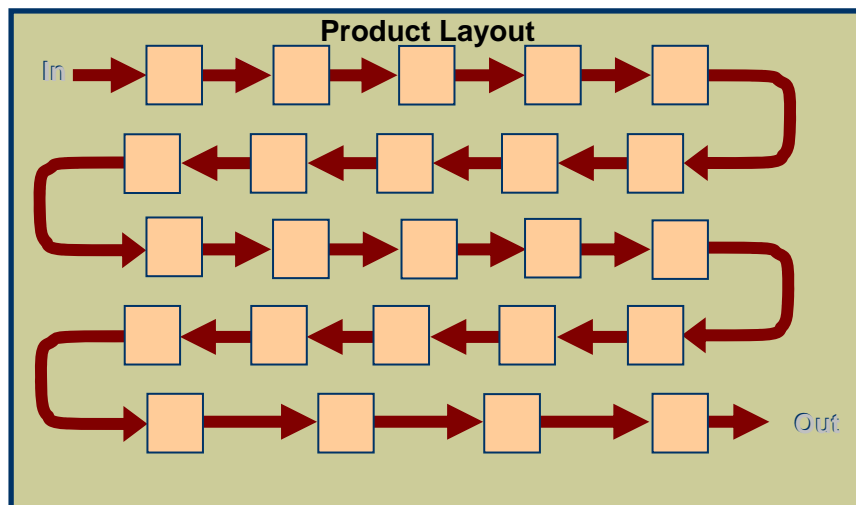

Fixed Position Layouts

This layout is the only one suitable for its products that cannot be moved until nearly completed. They are too large, bulky, or fragile to be moved such as houses, ships, or airplanes. The highly skilled workers – such as carpenters, plumbers, electricians, and painters – come to the layout. Their specialized equipment, such as cranes, scaffolding, generators, or air compressors for painting, is rented for the project.



Designing Process Layouts

There is one primary consideration when designing a process layout: MINIMIZE MOVEMENT AND/OR MATERIALS HANDLING COSTS. Following that rule, work stations with the greatest interaction between each other should be as close as possible while those having the least amount of contact with the others should be placed at the fringes of the work area unless some safety, construction, or cost consideration must take precedence.

There are two commonly used methods of approaching the layout design:

- **Block diagramming** – use to minimize nonadjacent workloads or when quantitative data is available
- **Relationship diagramming** - based on location preference between areas or when quantitative data is not available

Block Diagramming

We use historical data or talk with experienced employees to estimate the presumed movement between two work stations. We will express our finding in terms of “loads” and distance to move that load. The content and weight of the load depends on the business. It may be palletized for moving with a forklift like lumber that a cabinet maker would use, in baskets of sub-documents that an employee would carry for a document processing business, or parts of a meal that an employee of a fast-food restaurant would assemble and hand to the customer on a tray.

Begin developing the block diagram by listing all the work stations involved in the process. We will list them here as A, B, C, D, and E. Then list the possible combinations with the typical daily load movement between them. (A-B reads as “going from A to B.”)

Stations	Loads	Stations	Loads	Stations	Loads	Stations	Loads	Stations	Loads
A-	100	B-	0	C-	0	D		E-	0
A-	110	B-	200	C-	0	D		E-	0
A-D		B-	150	C-	40	D-	0	E	0
A-	0	B-	50	C-	50	D		E-	0

Obviously, there will be places that receive work but do not send it back into the system such as workstation “E” in our example which, by simply looking at the activity, indicates it’s the end of the production line. Materials from here do not come back into the layout but must go “outside the system”, i.e., out of the factory to the consumer.

Although this table is accurate regarding the data, it doesn’t tell us much about the potential layout. But, if we construct a simple grid to understand the flow better, it all becomes more visible. Especially the 150 loads moving between non-adjacent locations (dotted lines).

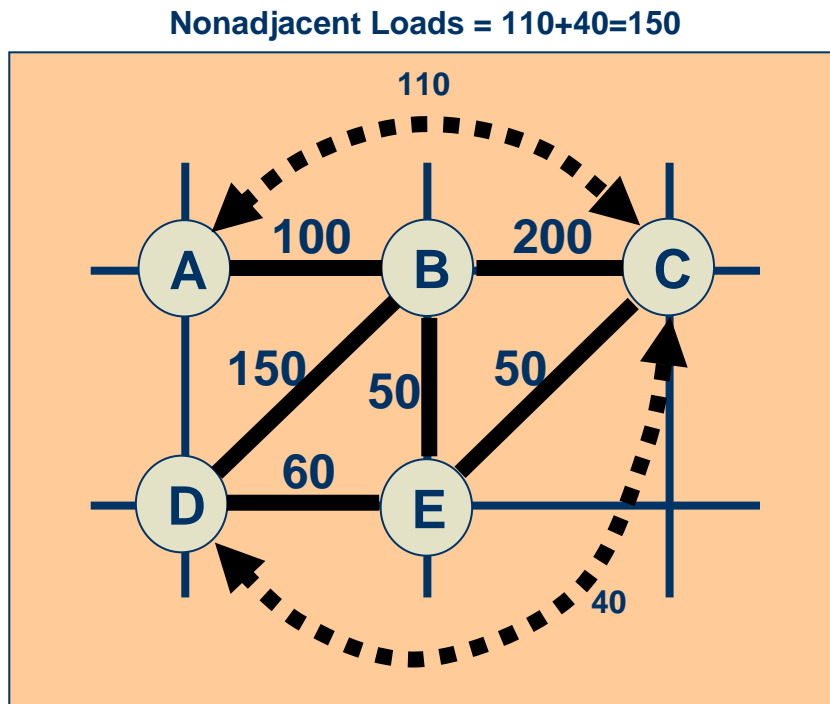

A little change in the work locations of the future facility can greatly improve the workflow like this. The same amount of loads move but there is no long trips around work stations as in the first diagram.

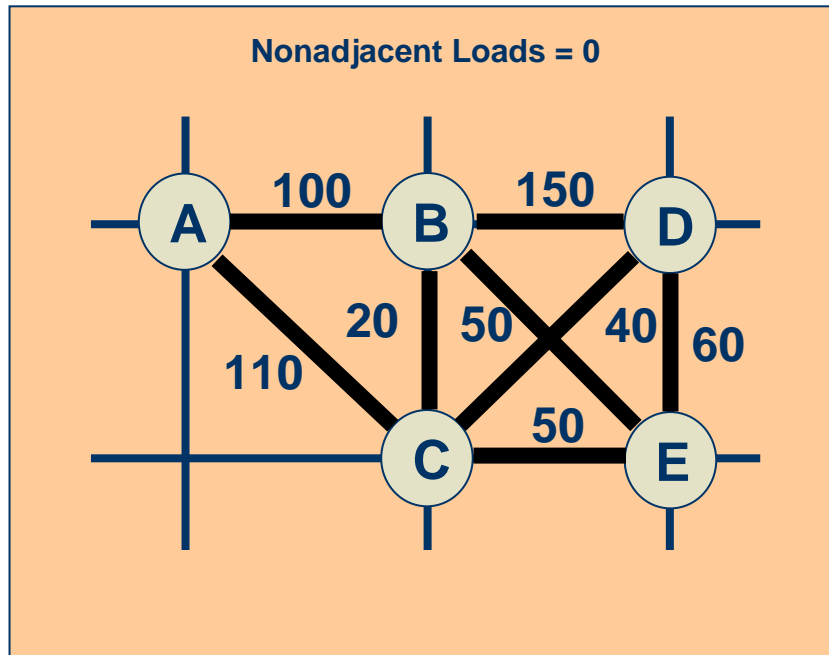

Now that you have a better positioning of the work stations by eliminating all of the nonadjacent workloads, you can use that layout as a basic for the building plans. Many vendors provide templates for the space required for their equipment installation and maintenance and will help you begin to sketch the layout. Since this is not a design course, we won't go into great detail. Suffice it to say the diagram above can easily become these block diagrams.

(a) Initial block diagram

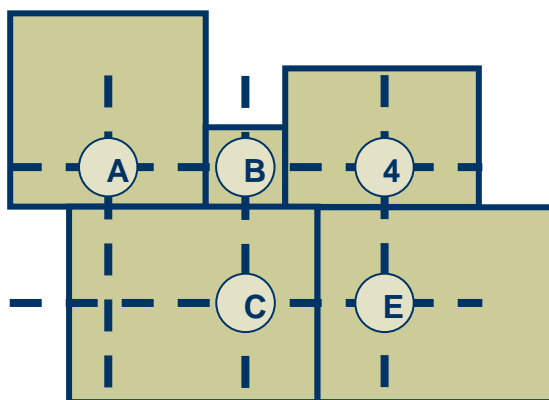

(b) Final block diagram

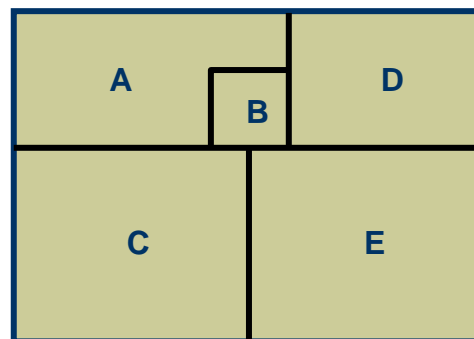

Relationship Diagramming

If quantitative data is not available or moving large amount of material is not relevant to the organization's function, a relationship diagram is very useful when managers want to plan the layout of their department. (This planning tool, a *Muther's Grid*, was devised by Richard Muther, an Industrial Engineer, in 1956 and has grown in use well beyond the scope of this course.)

Like all good tools in engineering, it is based upon a simple concept that can be applied universally. The preference information for the location of offices is based on the familiar five vowels used in English: A, E, I, O, and U with the letter X added. The letters help us remember the preference code used in the grid. "A" means "absolutely necessary", "E" is "especially important", "I" means simply "important", "O" is "okay", "U" is "unimportant", and "X" is "undesirable." As you can see, they descend in logical order from absolutely necessary to undesirable.

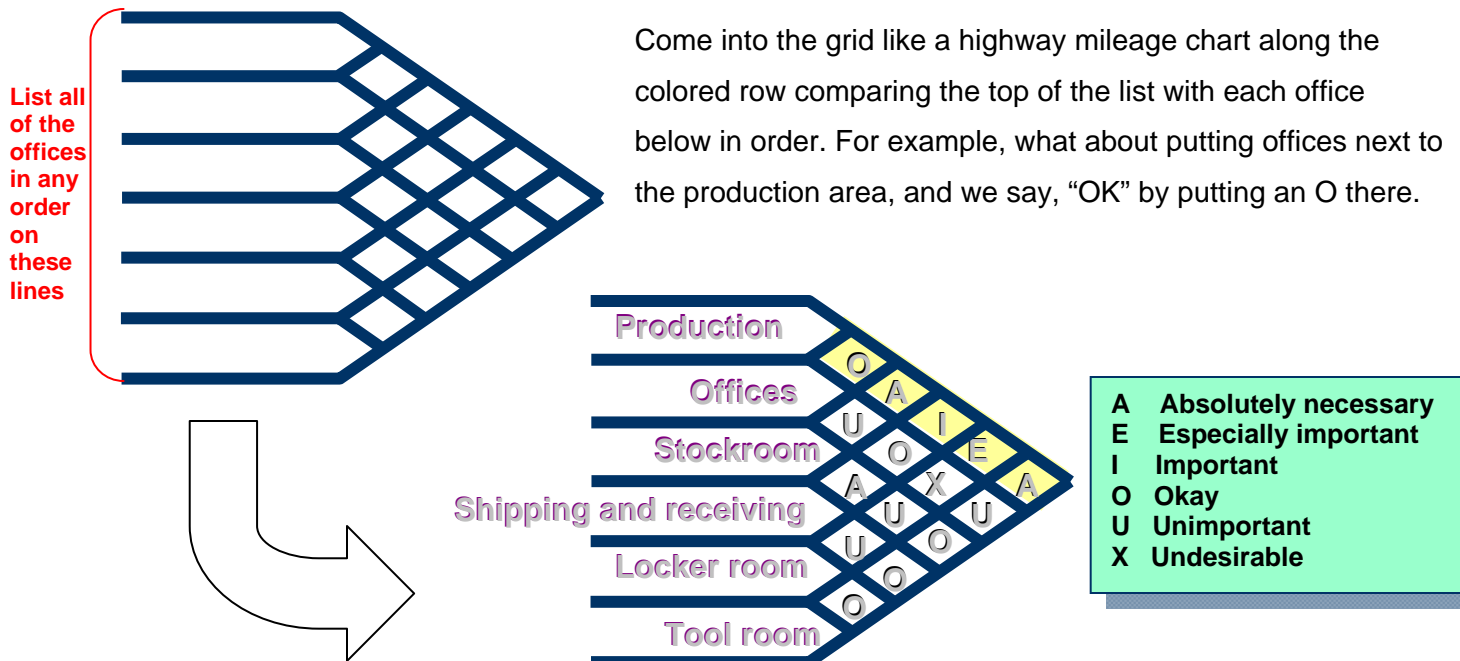

This final look at the grid tells us the department manager says (among other things), "It's OK (O) if offices are next to production, absolutely necessary (A) that the stockroom be next to production, important (I) that shipping and receiving be next to production but that the offices MUST NOT (X) be next to the locker room."

Once you have decided on the preference for the placement of the offices using a Muther's Grid, you can represent the importance of your choices of A, E, I, O, U, or X using a series of lines like this:

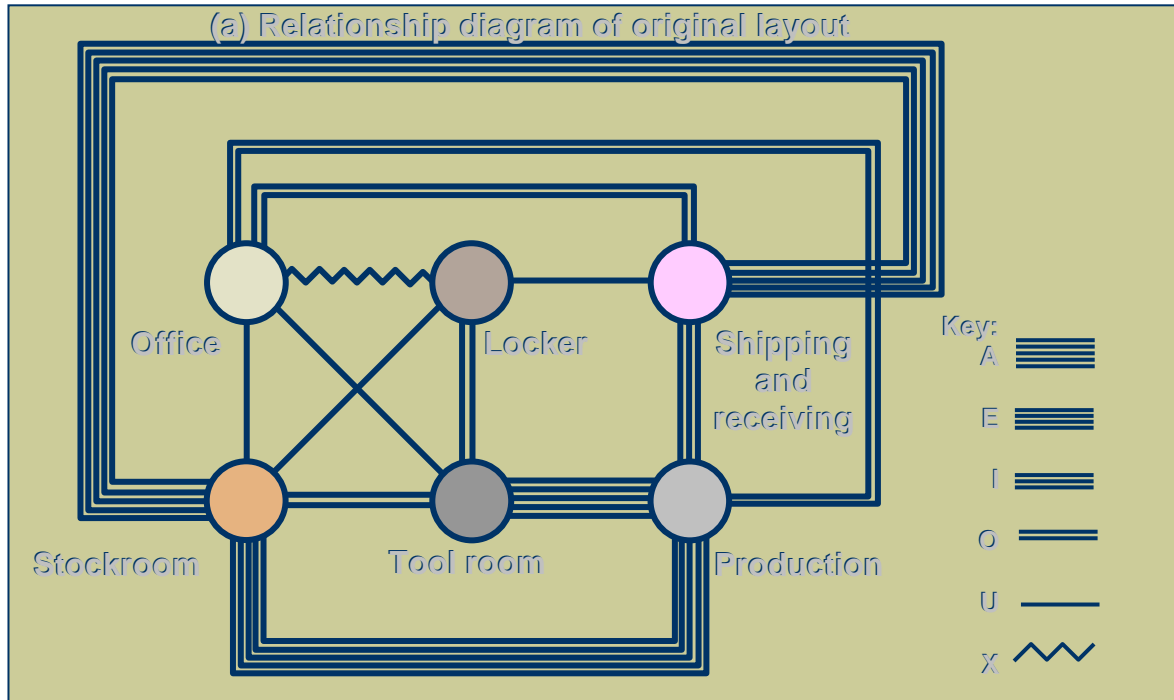

Clearly, we see in this diagram those three stations with great importance for each other, the stockroom, production, and shipping and receiving, are too far apart for maximum efficiency. Also, the locker room should not be next to the offices. So, if we rearrange the offices based on the Muther Grid showing our preferences, we will get a traffic pattern like this.

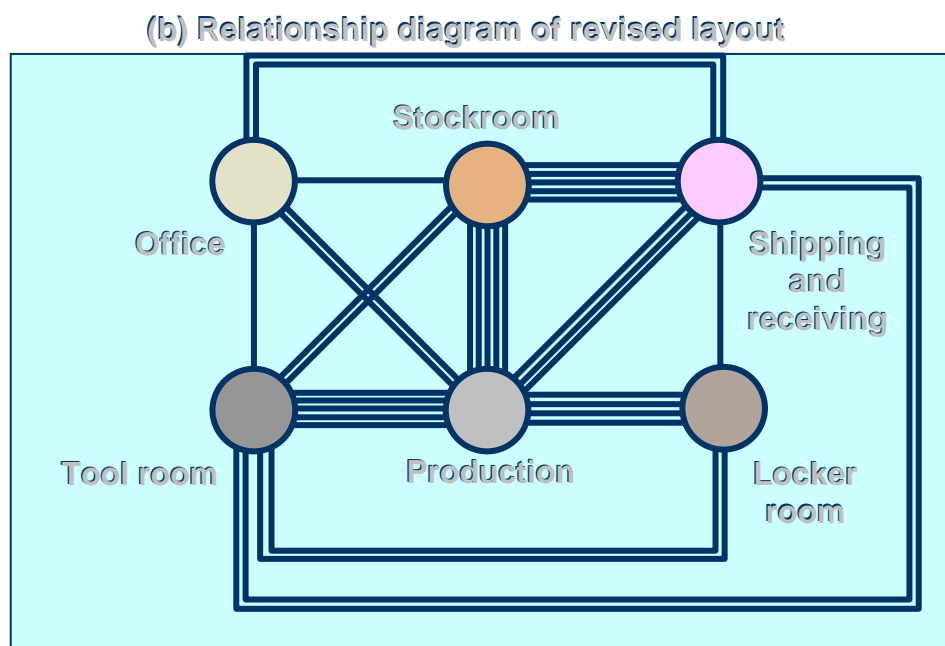

Designing Service Layouts

Service layouts frequently follow production layouts from the perspective of smooth flows of traffic but in retail outlets, the businesses' objectives will influence parts of the layout.

For example, a grocery store will arrange its shelves with milk at one end of the store with bread at the other to lead customers along a path of attractive displays, much lighting, and sale items as they fill their shopping carts. Retail clothing outlets encourage shoppers to browse around randomly spending as much time as possible at every counter.

Some typical layouts:

- **Free flow** - encourages browsing, increases impulse purchasing, are flexible and visually appealing
- **Grid** - encourages customer familiarity, are low cost, easy to clean and secure, and good for repeat customers
- **Spine and Loop** - both increase customer sightlines and exposure to products, while encouraging customer to circulate through the entire store

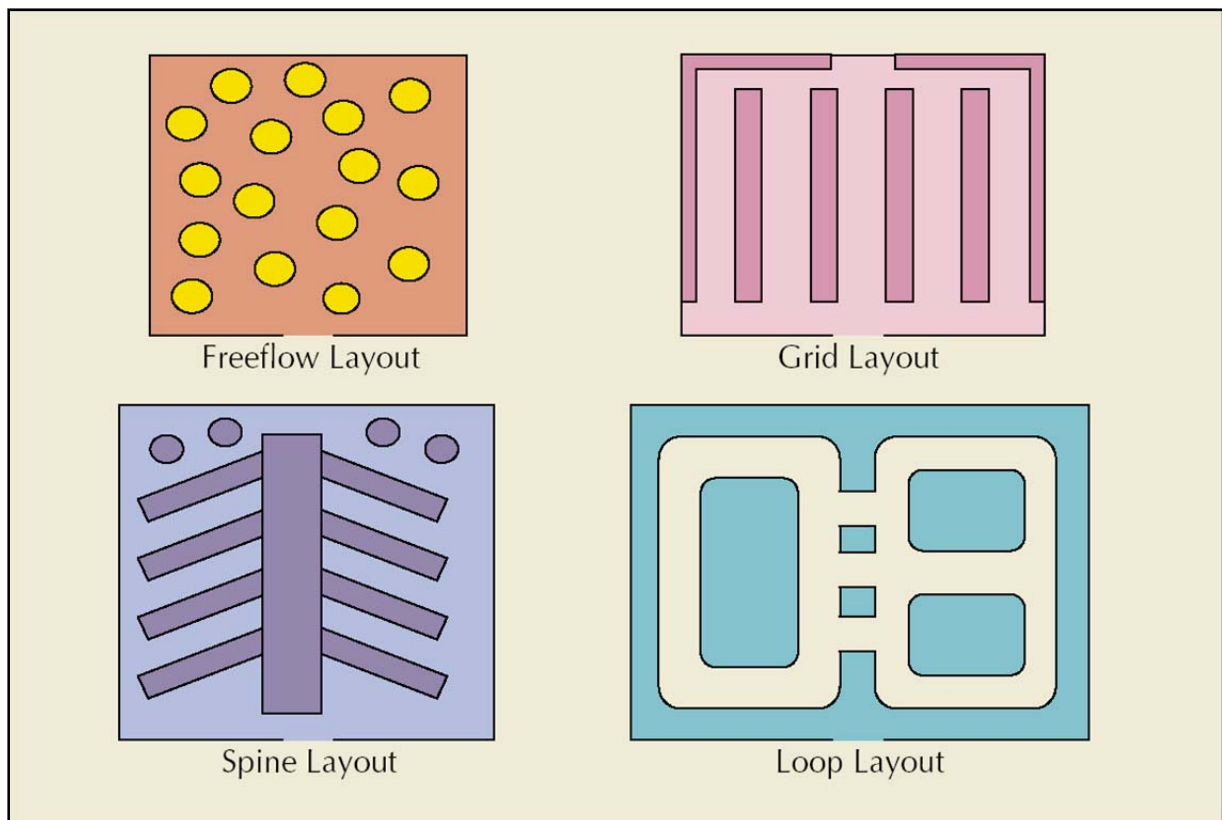

Designing Product Layouts

The product layout is the basic assembly line of sequential tasks that Henry Ford immortalized when he created the American auto industry. Although a very straightforward concept, there are some considerations necessary to optimize the potential speed and efficiency of the line. These 'optimization' topics are what we will consider next.

Some terms that we will use are

- **Precedence requirements** - tasks that must be completed before doing the next one such as testing the components inside a radio before sealing the outer shell.
- **Precedence diagram** – a drawing showing the assembly line with work stations arranged so as to honor the precedence requirements
- **Work station** – any place along the line where work is done on the product
- **Line balancing** – the process of equalizing the amount of work at each work station so the line keeps moving and no back-ups occur
- **Cycle time** – the maximum amount of time a part in the assembly process can spend at any single workstation in order to meet production requirements in a balanced line. We emphasize “can spend” because we want to meet some production criteria. Do not confuse this with “does spend” which is the amount of time a part may spend at a station if the line is not balanced.
- **Flow time** – the amount of time it takes a product to emerge from the end of the production line in comparison to when it entered the line. This includes all time spent waiting at any workstation.
- **Line efficiency** – is the ratio of the time spent doing work to the overall flow time of an assembly line. The overall flow time may include some idle time at one workstation while work at another takes a little longer for completion. For example, if the flow time for a product is 200 seconds which includes 40 seconds of idle time at one workstation while

work is being done at another, the amount of time the machines were working was $200 - 40 = 160$ seconds. Then $160/200 = 80\%$ efficient.

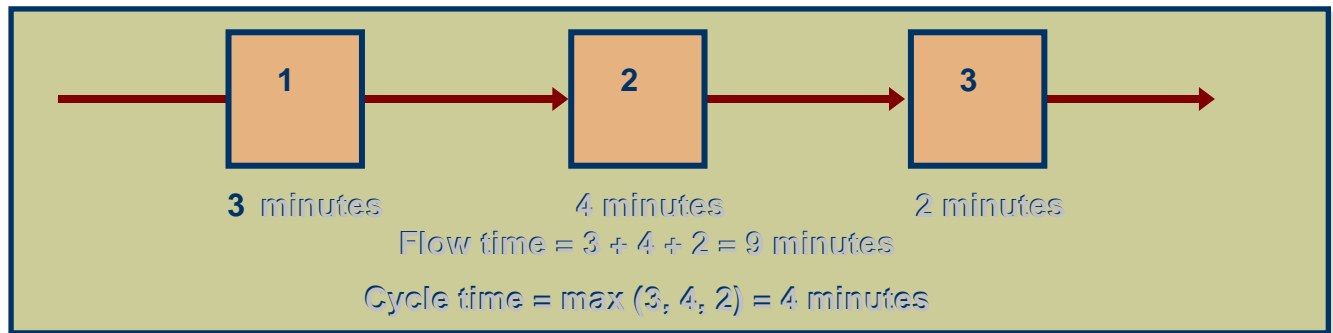

Think
about...

Let's talk about **cycle time** and see how the term, "the maximum time that can be spent at a work station" applies in a production setting.

Suppose a company wants to produce 200 radios in an eight hour day (or work shift.) The first thing we must do is break the hours into minutes to get the smallest practical time unit available. Therefore, an eight hour day (or shift) is also equal to 8 hours x 60 minutes in an hour = 480 minutes. So we now know the company wants to produce 100 radios within 480 minutes.

Our formula for cycle time is $C_t = \text{production time available} / \text{desired units of output}$ or $480/100 = 4.8$ minutes. This means the longest time a radio can spend at any workstation is 4.8 minutes.

It does not matter how many work stations you have in the process because this assumes the radios are working their way along the assembly line continuously. What it DOES TELL YOU is the longest it can sit *at any one station is 4.8 minutes* if you expect to produce 100 radios in 480 minutes.

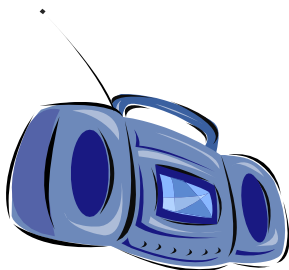

Next, we will look at **line balancing** which is fundamentally a trial and error process.

Let's suppose we work for the Big Sound Radio Manufacturing Company. The company designed a new model, called the Big Blaster that they think will be a huge seller.

Based on the drawings we have seen, it looks like there are eight steps in the production process with an estimated time (in seconds) of how long each step should take. This is the sequence of tasks and the length of time to do each. (Time expressed in seconds)

Work Station	Process	Task Time (seconds)
1	Receive the new radio shell, clean it, and place on conveyor belt. (Do this first.)	12
2	Install internal speakers	45
3	Install AM & FM receivers	120
4	Solder all electrical connections - melt weld all plastic connections	30
5	Attached the 120 volt electrical cord to the radio	42
6	Attach the back to the radio (only after all internal work is done)	25
7	Test the radio on AM & FM receivers.	15
8	Place in box, send to shipping department, and get ready for the next one. (This must be done last.)	8

This is what we must determine: (come back and answer these as we move through the lesson.)

- If we set up the production line with the eight steps and times shown above, what will be the **cycle time** per radio? _____
- If we set up the production line with the eight steps and times shown above, what will be our **production capacity** for each eight-hour shift? _____
- If we set up the production line with the eight steps and times shown above, what will be our **production efficiency** for each eight-hour shift? _____
- What is the **best line balancing** we can achieve each shift? (You will see which choice is best.) This is how we will find the answers to these questions.

We will look a little closer at the proposed production schedule.

Work Station (w/s) #	Process	Task Time	Longest time for any task	Idle time waiting for next w/s
1	Receive the new radio shell & clean it. (This must be done first.)	12		
2	Install internal speakers	45		
3	Install AM & FM receivers	120		
4	Secure all connections	30		
5	Attach the 120 volt cord	42		
6	Attach the back (internal work must be completed first.)	25		
7	Test the AM & FM receivers	15		
8	Place in box for shipping. (This must be last.)	8		
	Time in seconds	297		



These are typical questions to consider in a production environment.

- What is the longest time for any single task? _____ Write this amount in each cell in that column. Why should we do that? (This becomes evident soon, also.)
- Can additional tasks be completed and moved before the longest task is finished?

- What impact does that “longest task” have on the whole work cycle? (Everything else stops until this part is completed)
- Write in the amount of idle time at each station while waiting for the longest task to be completed.

Some questions we can ask at this point:

- Is this the only sequence that we can have? (**Answer:** The step at station #1 must come first and placing in a shipping box must come last.)
- Steps 2 & 3 can be reversed if neither must come before the other and there isn't some other reason why we can't such as having the AM & FM receivers in the cabinet would

make it hard to install the speakers. We will have to talk to the workers who actually do this to find the answer. (Talking to the people doing the work is a simple concept many managers do not understand.)

- Step 4 can only come after we make the connections.
- Step 5 must have something inside the radio to which we can attach the cord.
- Step 6 must come now because we cannot put on the back until everything is placed inside.
- Step #8 must be last because it goes to shipping after assembly.
- The only flexibility we have is reversing steps 2 & 3 if that would help.
- What is the longest time spent at any workstation? (**Answer:** 120 seconds at step 3.)
- What happens to the whole assembly line while step #3 occurs? (**Answer:** The whole line stops and waits.)

This is what production actually looks like with all workstations filled and taking into account delays while longer processes are completed.

Work Station #	Process	Task Time	Longest time for any task	Idle time waiting for next work station
1	Receive the new radio shell & clean it. (This must be done first.)	12	120	108 (We work for 12 seconds and wait for another 108 until station 3 completes it work of 120 seconds.)
2	Install internal speakers	45	120	75
3	Install AM & FM receivers	120	120	0
4	Secure all connections	30	120	90
5	Attach the 120 volt cord	42	120	78
6	Attach the back (we must complete internal work first.)	25	120	95
7	Test the AM & FM receivers	15	120	105
8	Place in box for shipping. (This must be last.)	8	120	112
	Time in seconds	297	960 Flow Time	663

This is an important consideration that must not be overlooked when looking at production - **the longest time spent at any workstation delays every workstation once the line is “full” and each station is engaged in production.**

More Questions

1. If we set up the production line with the eight steps and times shown above, what will be our production capacity for each eight-hour shift?

We have seen that it takes 960 seconds for a complete “flow” in the assembly of one radio. Since our answer for flow time is expressed as seconds, we must convert our 8-hour work shift to seconds so we are dealing with similar amounts.

The 8-hour shift has 60 minutes in each hour with 60 seconds in each minute. Therefore, $8 \times 60 \times 60 = 28,800$ seconds per shift. If it takes 960 seconds to build a radio and we have 28,800 seconds on the shift, we can build $28,800 \div 960 = \mathbf{30 \text{ radios per shift}}$.

2. If we set up the production line with the eight steps and times shown above, what will be our production efficiency for each eight-hour shift?

We found the flow time to be 960 seconds. During this time, work is being done for only 297 seconds: the rest of the cycle is idle time waiting for the longest task to be completed so the line can move again. The efficiency of the line is determined by dividing the total work time within a flow by the length of the work flow. **This is $297 \div 960 = 30.9\%$ efficient.**

3. What is the **best line balancing** we can achieve on each shift?

We will rearrange the tasks slightly to reduce as much idle time as possible. We will still acknowledge the sequence requirements (which step must come before any others) as we do this.

Work Station #	Process	Task Time	Longest time for any task	Idle time waiting for next w/s
1	Receive the new radio shell & clean it. (This must be done first.)	12	12	108
2	Install AM & FM receivers	120	120	0
3	Install internal speakers	45	117	20
	Secure all connections	30		
	Attach the 120 volt cord	42		
	Total time at this workstation =	117		
4	Attach the back (internal work must be completed first.)	25	48	72
	Test the AM & FM receivers	15		
	Place in box for shipping. (This must be last.)	8		
	Total time at this workstation =	48	120	72
	Time in seconds	297	480	183

These are sequence priorities.

Put the longest task as close to the front as you can while still acknowledging sequence priorities.

Put the next longest task next.

We collapsed eight separate steps into four, grouped three steps together for completion (117 seconds) as station #3 while waiting for step #2, and three steps at station #4 for 48 seconds. This means we can save money on purchasing workstations and hiring workers for each station.

Work flow time remains at 297 seconds because it still takes the same amount of work to build each radio. However, we have reduced the waiting time significantly. This means the **cycle time** is lower, too. This means we can produce more radios during each shift.

If it now takes 480 seconds to build a radio and we have 28,800 seconds on the shift, we can build $28,800 \div 480 = 60$ radios per shift.

Efficiency is now $297 \div 480 = 61.9\%$.

The next page contains a sample of how a spreadsheet and charts would look as we compare the current production with our proposed.

This is the current process with 8 workstations.

THE CURRENT PROCESS OF PRODUCING RADIOS

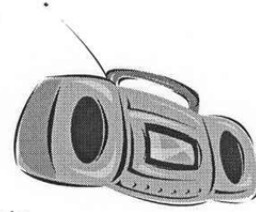

Note: When we do these calculations, we are looking for *very close approximations, not exact amounts*. We do not measure the time spent as the first few products move into the assembly line and fill all the work stations (w/s) nor the time spent as the production line empties at the end of the day.

Work Station #	All times are in seconds	Time to do the task and move it to the next w/s	Longest time any one task	Idle time waiting for the longest task to end.
1	Receive the new radio shell, clean it, place on conveyor belt. (This must be done first.)	12	120	108 seconds waiting after the production line is "full"
2	Install internal speakers	45	120	75 seconds waiting after the production line is "full"
3	Install AM & FM receivers and connect to speakers	120	120	0 seconds waiting after the production line is "full"
4	Solder all electrical connections - melt weld all plastic connections	30	120	90 seconds waiting after the production line is "full"
5	Attached the 120 v. electrical cord to the radio	42	120	78 seconds waiting after the production line is "full"
6	Attach the back to the radio (only after all internal work is done)	25	120	95 seconds waiting after the production line is "full"
7	Test the radio on AM & FM receivers.	15	120	105 seconds waiting after the production line is "full"
8	Place in box and send to shipping dept. And ready for next. (This must be done last.)	8	120	112 seconds waiting after the production line is "full"

Seconds of actual work to produce a radio → 297

← 663 This is the time each radio spends waiting through the production line.

Given information			
shift/hrs.	min/hr.	sec/min	seconds of work per shift
8	60	60	28,800

↑ 960 This is the actual cycle time needed to move one radio through all of the work stations.

$$\text{Efficiency \%} = \frac{\text{Work Time}}{\text{Cycle Time}}$$

$$\text{or } E\% = \frac{WT}{CT} = \frac{297}{960} = 30.9\% \text{ Line Efficiency}$$

$$\text{Radios produced/shift} = \frac{28,800 \text{ seconds in a shift}}{960 \text{ seconds to produce each radio}} = 30 \text{ radios/shift}$$

Check your calculations!!
TOTAL CYCLE TIME SHOULD EQUAL WORK TIME + WAITING TIME.
 Work time = 297
 Wait time = 663
 Total cycle time = 960

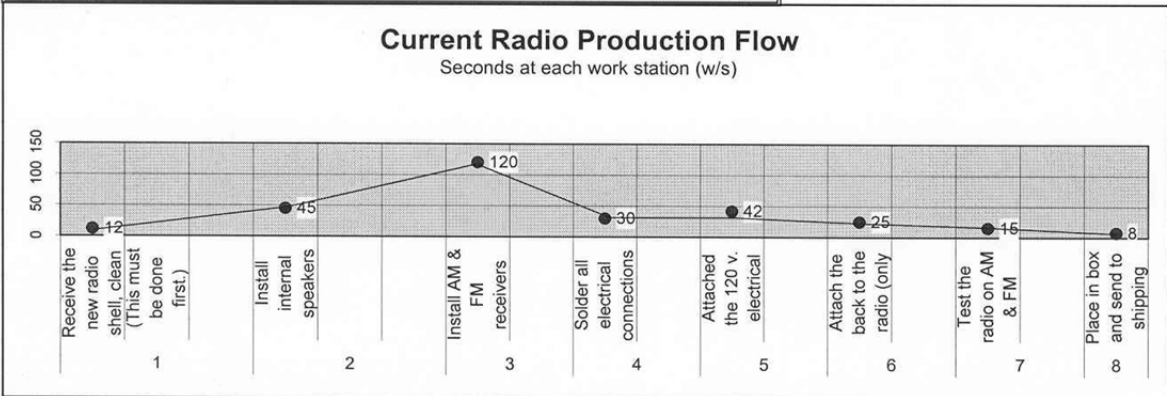

THE PROPOSED PROCESS OF PRODUCING RADIOS

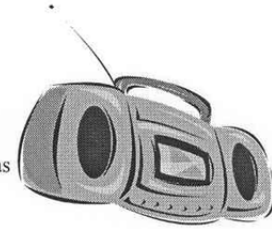

We will put as many tasks as each station as possible with these limitations:

1. We acknowledge the tasks that must be first and last by putting them first and last.
2. We put the longest task as close as we can to the front of the line.
3. We group all other tasks which to do have a prerequisite in descending assembly time at each station so long as assembly time at each w/s does not exceed the LONGEST task in the whole line.

Work Station #	All times are in seconds	Time to do the task and move it to the next w/s	Longest time any one task	Idle time waiting for the longest task to end.
1	Receive the new radio shell, clean it, place on conveyor belt. (This must be done first.)	12	120	108 seconds waiting after the production line is "full"
2	Install AM & FM receivers Note: We still connect speakers and receivers at w/s #3	120	120	0 seconds waiting after the production line is "full"
3	Install internal speakers and connect to receivers Solder all electrical connections - melt weld all plastic connections Attached the 120 v. electrical cord to the radio	45 30 42 <u>117</u>	120	3 seconds waiting after the production line is "full"
4	Attach the back to the radio (only after all internal work is done) Test the radio on AM & FM receivers. Place in box and send to shipping dept. And ready for next. (This must be done last.)	25 15 8 <u>48</u>	120	72 seconds waiting after the production line is "full"
		297	480	183

Given information			
shift/hrs.	min/hr.	sec/min	seconds of work per shift
8	60	60	28,800

Efficiency % = $\frac{\text{Work Time}}{\text{Cycle Time}}$ or $E\% = \frac{WT}{CT} = \frac{297}{480} = 61.9\%$ Line Efficiency

Radios produced/shift = $\frac{28,800 \text{ seconds in a shift}}{480 \text{ seconds to produce each radio}} = 60$ radios/shift

Check your calculations!!
TOTAL CYCLE TIME SHOULD EQUAL WORK TIME + WAITING TIME.
 Work time = 297
 Wait time = 183
 Total cycle time = 480

Proposed Radio Production Flow

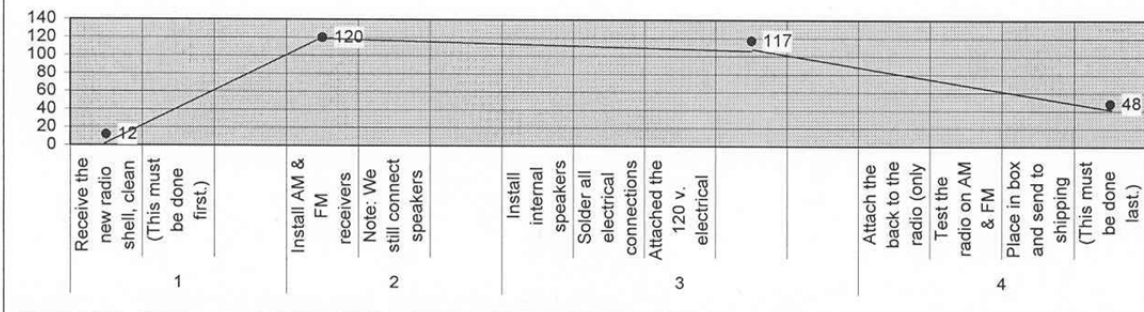

Designing With Precedence Considerations

Here is another way of line balancing that considers the precedence requirements as we package food. We will use the information in the boxes below.

1. Draw and label a precedence diagram
2. Calculate desired cycle time required for line (the most that can be spent at any one station and still give us the daily production we need)
3. Calculate theoretical minimum number of workstations (we will do this next)
4. Group elements into workstations, recognizing cycle time and precedence constraints
5. Calculate the efficiency of line
6. Determine if theoretical minimum number of workstations or an acceptable efficiency level has been reached. If not, go back to step 4.

	WORK ELEMENT	PRECEDENCE	TIME (MIN)
A	Press out sheet of fruit	—	0.1
B	Cut into strips	A	0.2
C	Outline fun shapes	A	0.4
D	Roll up and package	B, C	0.3

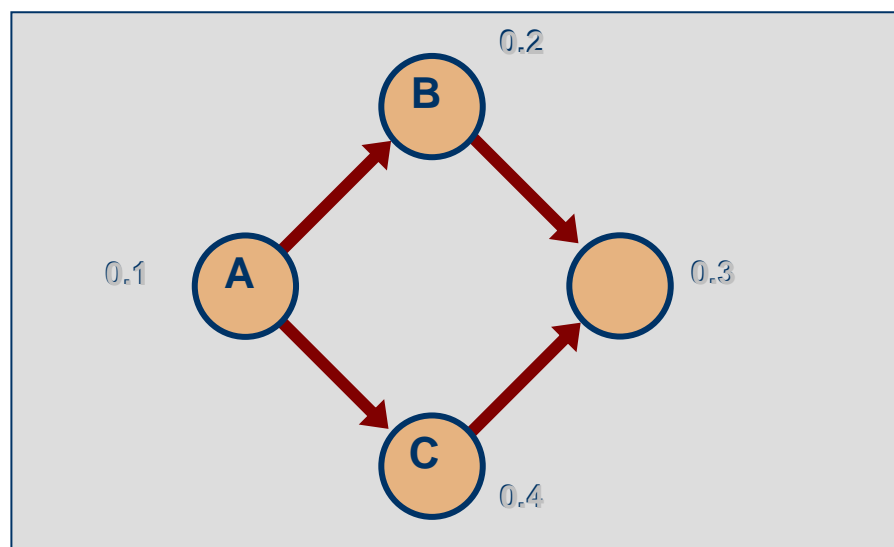

How many workstations will we need to have for this example?

	WORK ELEMENT	PRECEDENCE	TIME (MIN)
A	Press out sheet of fruit	—	0.1
B	Cut into strips	A	0.2
C	Outline fun shapes	A	0.4
D	Roll up and package	B, C	0.3

This assumes a 40 hour production week and a desire to produce 6,000 units per week. First, we convert 40 hours into minutes by multiplying 40 hours x 60 minutes/hour to get 2,400 production minutes per week.

If we want to produce 6,000 units during these 2,400 minutes, we see we have only .4 minutes available to produce one item (2,400/6,000 = .4)

Our chart above shows the maximum cycle time is .4 minutes at step C and the flow time is 1.0 minutes (.1 at A; .2 at B, .4 at C, and .3 at D = 1.0 minute.)

$$\text{Cycle Time} = \frac{40 \text{ hours} \times 60 \text{ minutes / hour}}{6,000 \text{ units}} = \frac{2,400}{6,000} = 0.4 \text{ minute}$$

$$\text{Number of workstations required are} = \frac{0.1 + 0.2 + 0.3 + 0.4}{0.4} = \frac{1.0}{0.4} = \rightarrow 3 \text{ workstations} \\ \text{(We cannot have less than a whole workstation)}$$

Here is the line balancing calculation for this process:

Cycle Time = 0.4

Number of workstations needed = 2.5

(i.e., 3 stations since we can't have less than a whole one.)

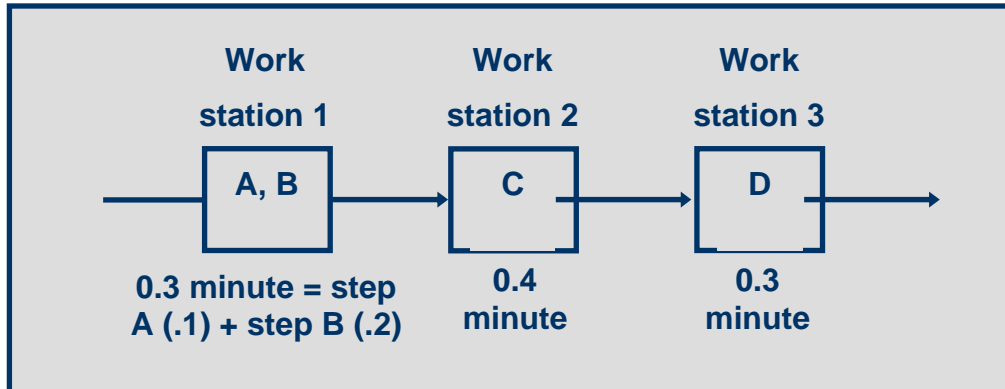

$$E = \frac{0.1 + 0.2 + 0.3 + 0.4}{3 \times (0.4)} = \frac{1.0}{1.2} = 0.833 = 83.3\%$$

Total working time
Flow time = working time + idle time

3 workstations x the longest time at any one station (the cycle time of .4)

Here is another practice opportunity for streamlining an office workflow.

Department: Accounts Payable Date observed: June 23-24

Job Observed: Reimbursing expense reports

Observer: Logan Grant

OBSERVATION CODES

W = Working (doing what they are paid to do) **M** = Moving from work station
I = Idle (any time waiting or not working) **F** = Filing (Or storing something)

What comments can be made about improving the workflow based on this example?

Step #	Describe the Step	Code	Distance in feet	Time in min/sec	Comments
1.	Goes to incoming mail area to get expense reports and returns to work station (desk)	M	70' r/t	0:45	(next page)
2.	Opens envelope, organizes receipts.	W		1:15	
3.	Notices some expense code fields are empty, looks up proper codes.	W		2:10	
4.	Completes authorization to reimburse form on PC and send to the shared printer.	W		0:15	
5.	Goes to shared printer to get form	W	2	0:10	
6.	Waits while admin assistant finishes printing new parking policy. (Admin assistance goes to get more paper.)	I	60' r/t for admin	2:15	
7.	Takes printed form to boss for review and approval.	M	45	0:20	
8.	Boss on the phone – clerk waits	I		3:15	
9.	Goes to copier to make 2 copies of approved form	W	35	0:25	
10.	Copier toner low. Must find new cartridge and refill	W/I		3:50	
11.	Makes copies and back to desk	W	35	0:20	
12.	Cuts reimbursement check and places it into I/O envelope.	W		2:00	
13.	Starts at step 1 again				

Summary: Time for 1 complete work cycle: 16:50 minutes/seconds

Take a few minutes to consider each step. Then list some questions that you would ask about each step in this situation. At this point, we are not ready to make any recommendations for change: we are just asking questions to make sure we clearly understand the situation.

Comments about the Workflow

Step #	Describe the Step	Code	Distance in feet	Time in min/sec	Comments
1.	Goes to incoming mail area to get expense reports and returns to work station (desk)	M	70' r/t	0:45	Can we bring mail to them?
2.	Opens envelope, organizes receipts.	W		1:15	
3.	Notices some expense code fields are empty, looks up proper codes.	W		2:10	Print most common codes on the form? On-line reference?
4.	Completes authorization to reimburse form on PC. Sends to the shared printer.	W		0:15	
5.	Goes to the shared printer to get form	W	2	0:10	
6.	Waits while admin assistant finishes printing new parking policy. (Admin assistance goes to get more paper.)	I	60' r/t for admin	2:15	Store paper at printer? Dedicated printer for accounts payable?
7.	Takes printed form to boss for review and approval.	M	45'	0:20	Authorize clerks to OK up to a threshold?
8.	Boss on the phone – clerk waits.	I		3:15	
9.	Goes to copier to make 2 copies of approved form.	W	35	0:25	
10.	Copier toner low. Must find new cartridge and refill.	W/I	-	3:50	Check all copiers at end of day for toner and paper to be ready for next day?
11.	Makes copies and back to desk.	W	35	0:20	
12.	Cuts reimbursement check and places it into I/O envelope.	W	-	2:00	
13.	Starts at step 1 again.				

Although the comments made may not all lead to a change (would clerks REALLY be authorized to approve expenses up to a limit?), they do indicate some potential opportunities for process improvement.

And, when you think about it, that is what this course is all about...streamlining the workflow to increase your production capacity.